

# Assembly instruction

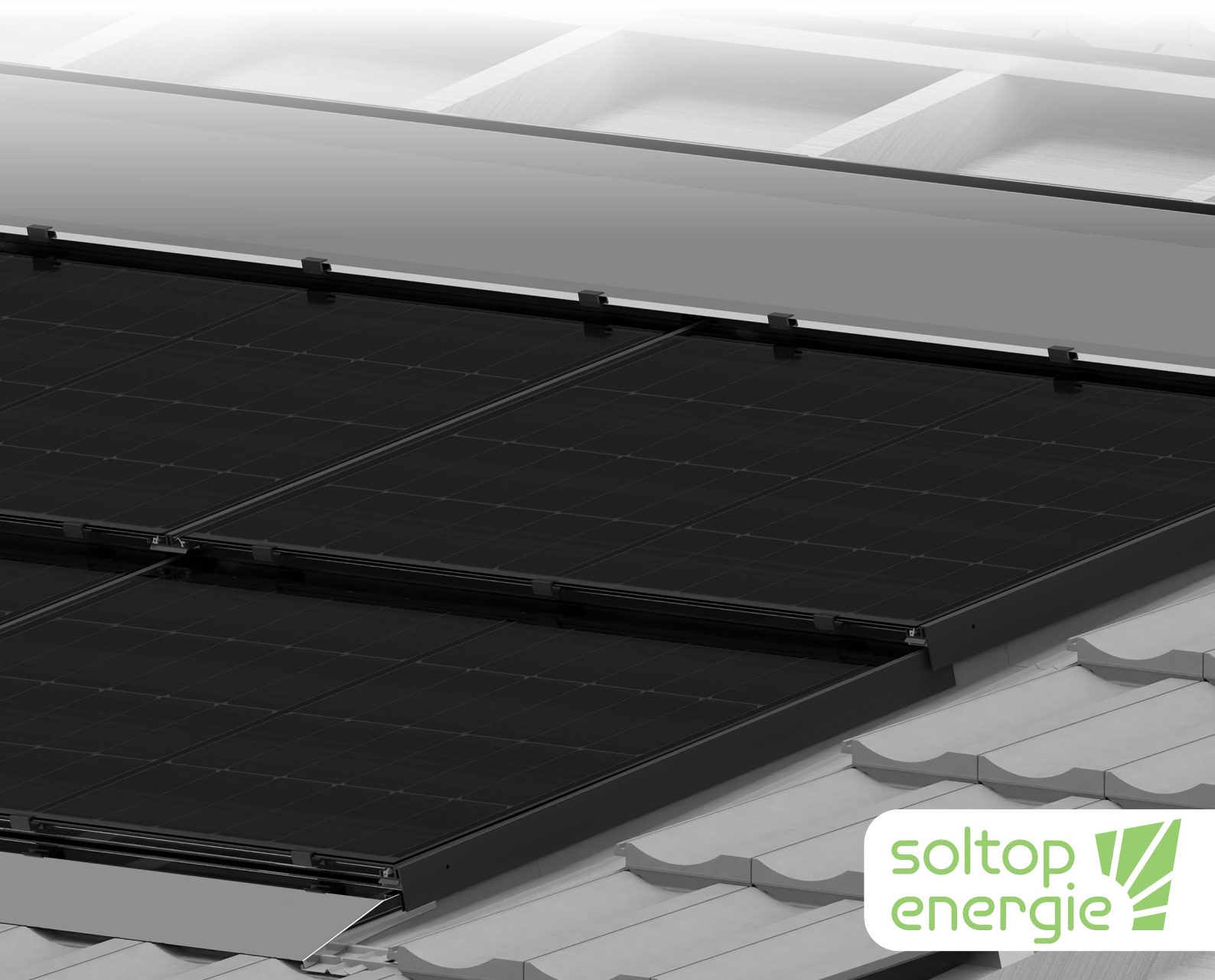

## Contents

Scope of validity of the instructions	3
Requirements for the roof	4
Preparation of the roof substructure	5
Safety instructions	6
Tool overview	7
Overview drawing	8
2.1 Measuring the module field	9
2.2 Positioning the first row of horizontal profiles	9
2.2.3 Fitting the fixing tabs	10
2.2.4 Setting the fixed point	10
2.3 Positioning further horizontal profile rows with spacer gauge	11
2.4 Installing the end profile	12
2.5 Installing support battens	13
2.6 Preparation for tinsmith work	14
2.7 Tinsmith work	15
2.8 Potential equalization	15
2.9 Installation of vertical gutter	16
2.10 Installing the in-situ and side end	17
2.11 Installing sealing profile pieces	18
2.12 Installation of modules	18
2.13 Blind module	19
<b>Attachment A</b>	20
Unwinding drawing: In-situ termination with blind modules S/M	20
Unfolding drawing: In-situ termination with blind modules snow guard	21
Unfolding drawing: In-situ termination with blind modules L	22
<b>Attachment B (planning documents)</b>	23
Details for complete roof covering (PV only)	23
Details for termination in tiles	24
Bend & in-situ details	26
Ridge details	27
Chimney	28
Velux windows	30

---

## Scope of validity of the instructions

These installation instructions only describe the installation of the SwissSolarRoof system. For the installation of other components (inverters, monitoring systems, etc.), please use the documents supplied by the respective manufacturer.

## Statics

The mounting system is calculated according to the standards SIA 260 (structural load) and SIA 261 (wind and snow load), as well as the applicable Eurocodes. The assembly must be carried out in accordance with the assembly plans and the structural analysis report supplied. The number of fixing points must not be reduced.

## Target groups

The SwissSolarRoof may only be installed and put into operation by persons who are able to ensure that the installation is carried out in accordance with the regulations due to their professional suitability (e.g. training or activity) or experience.

## Storage of the documents

The system operator must ensure that these installation instructions are available for maintenance if required.

## Lightning protection

Lightning protection measures must be planned by the installer in consultation with the relevant specialists.

## Warranty conditions

The “Warranty conditions for SOLTOP Energie products” valid at the time of purchase and the “General terms and conditions of sale” of SOLTOP Energie AG, CH-8353 Elgg apply.

## Maintenance

Photovoltaic systems are technical installations and require periodic inspection. We recommend regular visual inspection of the PV modules for soiling and module breakage. The inverter manufacturer’s monitoring portals allow you to check the yield and any faults that may occur. If you have any questions, please contact your installer.

## Scope of delivery

The delivery must be checked for completeness immediately upon receipt. Complaints can only be made on the day of delivery.

## Requirements for the roof

The roof structure must be designed for the additional forces generated by the photovoltaic system.

## Requirements for the sub-roof

The requirements for the sub-roof are specified in SIA 232.

Sub-roof according to SIA 232 requirements	
Roof pitch	Under-roof requirement
> 18° - 75°	Sub-roof for normal loads.
> 15° - 18°	Sub-roof for increased loads, joints tightly bonded.
> 10° - 15°	Sub-roof for exceptional loads, joints homogeneously welded and drainage in gutter.
5° - 10°	Sub-roof in flat roof quality with waterproof counter battens or welding of the counter battens and drainage in gutter.

---

## Installation requirements

- When installing the system, all information in these installation instructions must be observed.
- Only the components supplied by SOLTOP Energie AG may be used to install the “SwissSolarRoof”. SOLTOP Energie AG cannot accept any liability for the use of third-party products.
- Mounting systems from SOLTOP Energie AG are constantly being further developed and can therefore change on an ongoing basis, so the latest version of the installation instructions should always be used. Download via: <https://www.soltop-energie.ch/planungsunterlagen/>
- Equipotential bonding within and between the module fields must be implemented in accordance with country-specific regulations.

---

## Planning

The photovoltaic system is planned in the my.Soltop design software. If the design is to be taken over by SOLTOP Energie AG, all planning-relevant information must be provided. For an uncomplicated and quick design, we recommend that all customers use my.Soltop independently. You can plan your own system in just a few steps and receive your quote in no time at all: <https://my.soltop.ch/>

---

## Statics

My.Soltop calculates a structural analysis for each system and immediately produces a project-specific structural analysis report. The information in the structural analysis report must be adhered to during installation.

Output documents:

Once the system has been designed and calculated, the following output documents are created automatically by my.Soltop:

- Structural analysis report
- Module plan as PDF & DXF
- Installation plan

The information in the output documents is based on the input values from my.Soltop.

**Before starting the installation, check the roof dimensions and the position of the roof superstructures!**

## Preparation of the roof substructure

The roof substructure must be in good condition.

To ensure sufficient rear ventilation, the following values must be observed as a minimum.

For this purpose, the counter battens are usually raised accordingly.

The minimum ventilation space between the sub-roof and the covering is regulated by SIA 231/1 and depends on the length of the rafters, the roof pitch and the reference height.								
	Roof pitch and reference height high							
	<15°		15° to <20°		20° to <25°		>25°	
	<800m	>800m	<800m	>800m	<800m	>800m	<800m	>800m
Rafter length								
<b>&lt;5m</b>	45mm	60mm	45mm	60mm	45mm	45mm	45mm	45mm
<b>5 bis &lt;8m</b>	60mm	80mm	60mm	80mm	45mm	60mm	45mm	60mm
<b>8 bis &lt;15m</b>	80mm	100mm	80mm	100mm	60mm	80mm	60mm	80mm
<b>&gt;15m</b>	100mm	120mm	100mm	120mm	80mm	100mm	60mm	100mm

Extract from SIA 232/1;2011

Very good rear ventilation is required to ensure high efficiency of the in-roof photovoltaic modules. **We therefore recommend increasing the values listed in the table by 20 mm.** In accordance with SIA 232/1, the SwissSolarRoof in-roof system is considered an airtight covering. The air inlet and outlet openings must be designed accordingly.

The horizontal profiles of the mounting system are screwed to the counter battens at each intersection point. The counter battens should therefore form a flat surface for the SwissSolarRoof.

In the event of unevenness greater than a 20 mm cavity, we recommend doubling up with an additional roof batten.

If individual counter battens protrude, we recommend leveling the battens, e.g. by planing with an electric planer.









A gap of 4 mm or more between the horizontal profile and the counter battens must be filled.

**A well-prepared roof saves you a lot of time when sanding and leveling.**

## Safety instructions

Occupational safety and accident prevention regulations and the relevant SUVA standards and regulations must be observed!

### Explanation of the pictograms for the safety instructions

Safety pictograms (warning symbols)				Description
 Danger	 Electrical Voltage	 Hot surface	 Risk of falling	Warns of personal injury
 Attention	 Glass (fragile)	 Instructions read	 Transport and storage	

 Planning, installation and commissioning of the solar power system may only be carried out by qualified specialists. Improper execution can lead to damage to the system and the building and endanger persons.

 **Equipment**  
Personal protective equipment (PPE) must be worn.

 **Danger of falling**  
There is a risk of falling when working on the roof and when climbing up and down. It is essential to observe the SUVA accident prevention regulations and use suitable fall protection equipment.

 **Risk of injury**  
People can be injured by falling objects. Before starting installation work, cordon off the danger zone and warn people in the vicinity.  
Protective gloves must always be worn.

## Tool overview

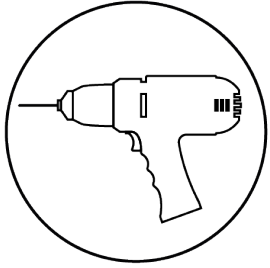

Cordless screwdriver

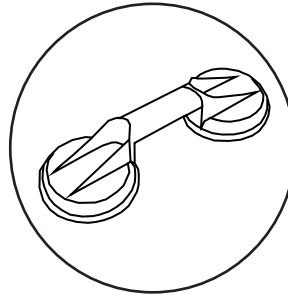

Suction lifter

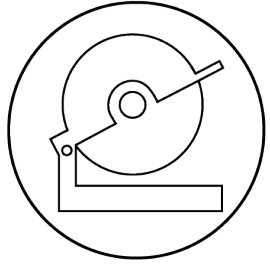

Crosscut saw

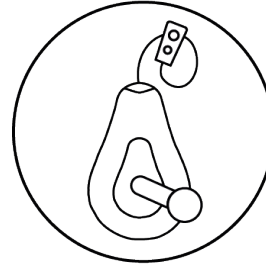

Impact cord

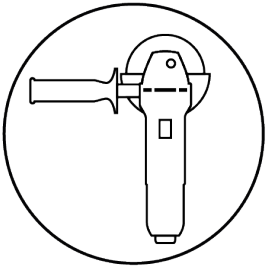

Angle grinder

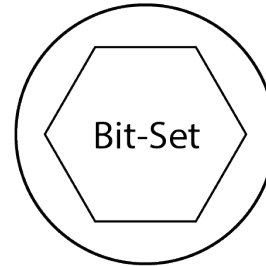

Bit Set

## Overview drawing

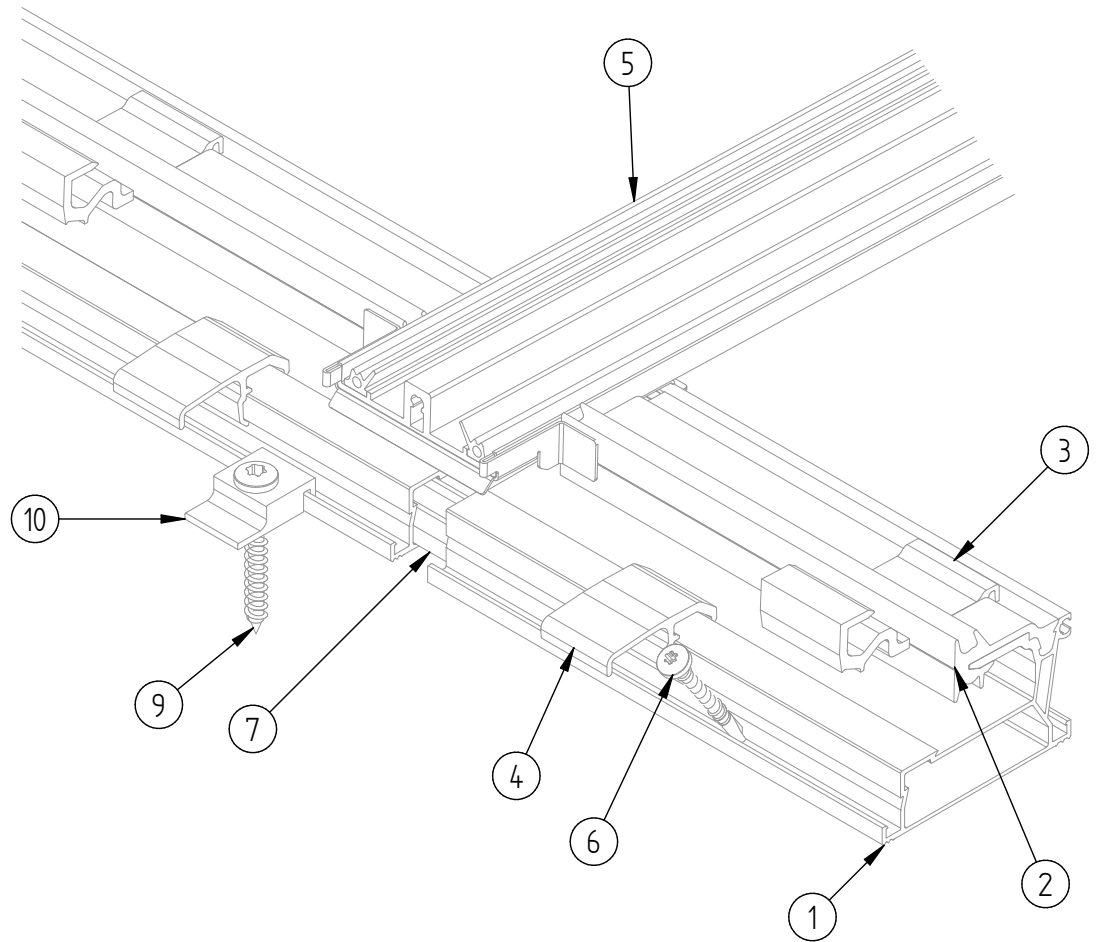

- |   |  |    |   |
|---|--|----|---|
| 1 | SwissSolarRoof Horizontal profile<br>Available in the following versions:<br>1S, 2S, 3S, 4S Modules<br>1ML, 2ML, 3ML Modules | 7  | SwissSolarRoof                              |
| 2 | SwissSolarRoof Sealing profile   | 8  | SwissSolarRoof                              |
| 3 | SwissSolarRoof Module holder   | 9  | Wood screw 6x50                             |
| 4 | SwissSolarRoof Support clip  | 10 | Mounting bracket                            |
| 5 | SwissSolarRoof Vertical channel  | 11 | Support slat 30x50                          |
| 6 | Self-tapping screw 4.9x35  | 12 | Support slat 24x48                          |
|   |  | 13 | SwissSolarRoof Distance gauge               |
|   |  | 14 | SwissSolarRoof Potential equalization cable |

### Optional:

- |    |                                     |    |                             |
|----|-------------------------------------|----|-----------------------------|
| 16 | SwissSolarRoof Side finish in brick | 18 | SwissSolarRoof Dummy module |
| 17 | SwissSolarRoof Local closure        | 19 | SwissSolarRoof Snow guard   |

## 2.1 Calibrating the module field

- Measure the field area on the roof according to the installation plan and the information in the planning documents (distance to roof edge, roof superstructures, etc.).
- Mark the position of the first row of horizontal profiles using a chalk line or laser.
- Check the right angle of the module array!

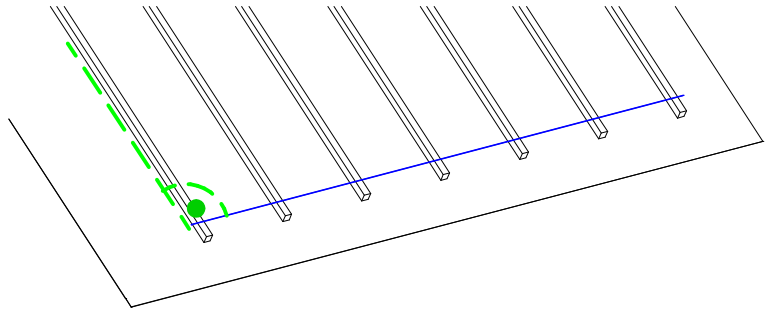

## 2.2 Placing the first row of horizontal profiles

### 2.2.1

- Position the measured continuous row of horizontal profiles according to the installation plan.
- Height differences between the horizontal profile and the counter battens of more than 4 mm must be compensated for with battens!

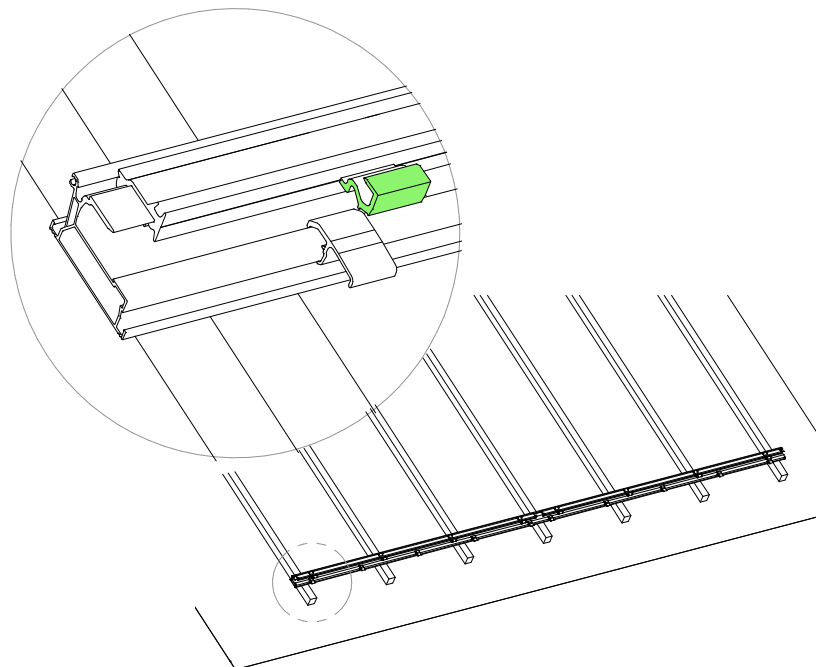

### 2.2.2 Connect profiles

- Slide the profile connector into the horizontal profile. The distance is given by the spacer!

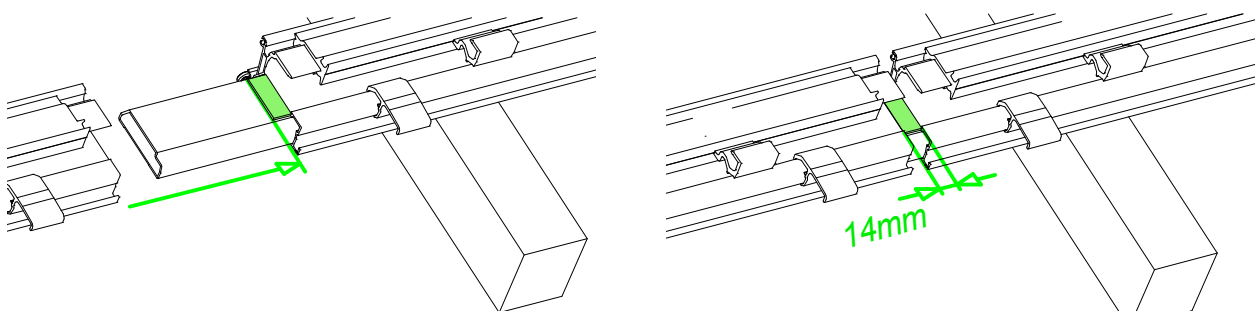

## 2.2.3 Fitting the mounting brackets

- Fastening brackets are fitted at each intersection point of the horizontal profile and counter batten.
- These are fastened to the counter battens with 6x50 wood screws.
- If only one fixing bracket is specified, it must be fitted alternately at the top/bottom.

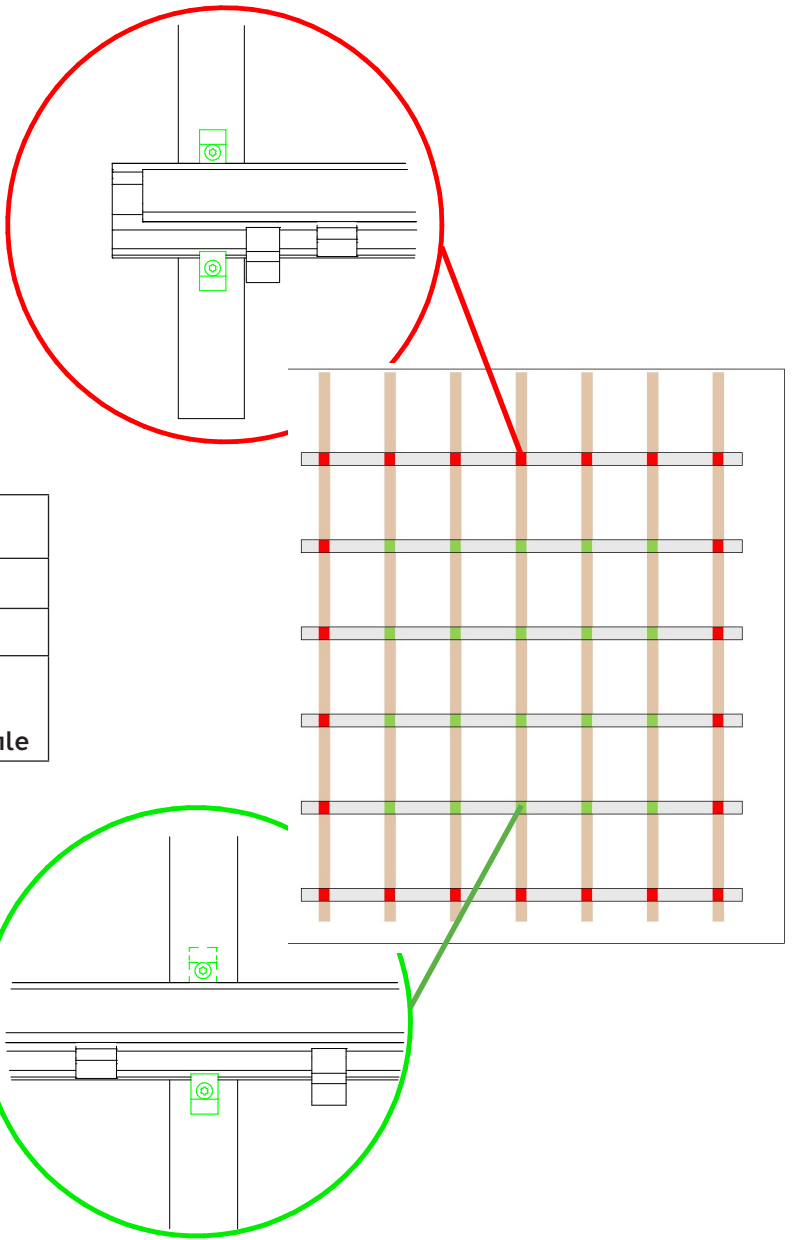

Number of fixing lugs	
in the edge area:	2
in the field:	see assembly plan
for snow guard modules:	2 on the lower and upper horizontal profile

## 2.2.4 Set a fixed point

- Screw each individual horizontal profile to the counter batten in the middle of the profile using a 4.9x35 self-tapping screw.

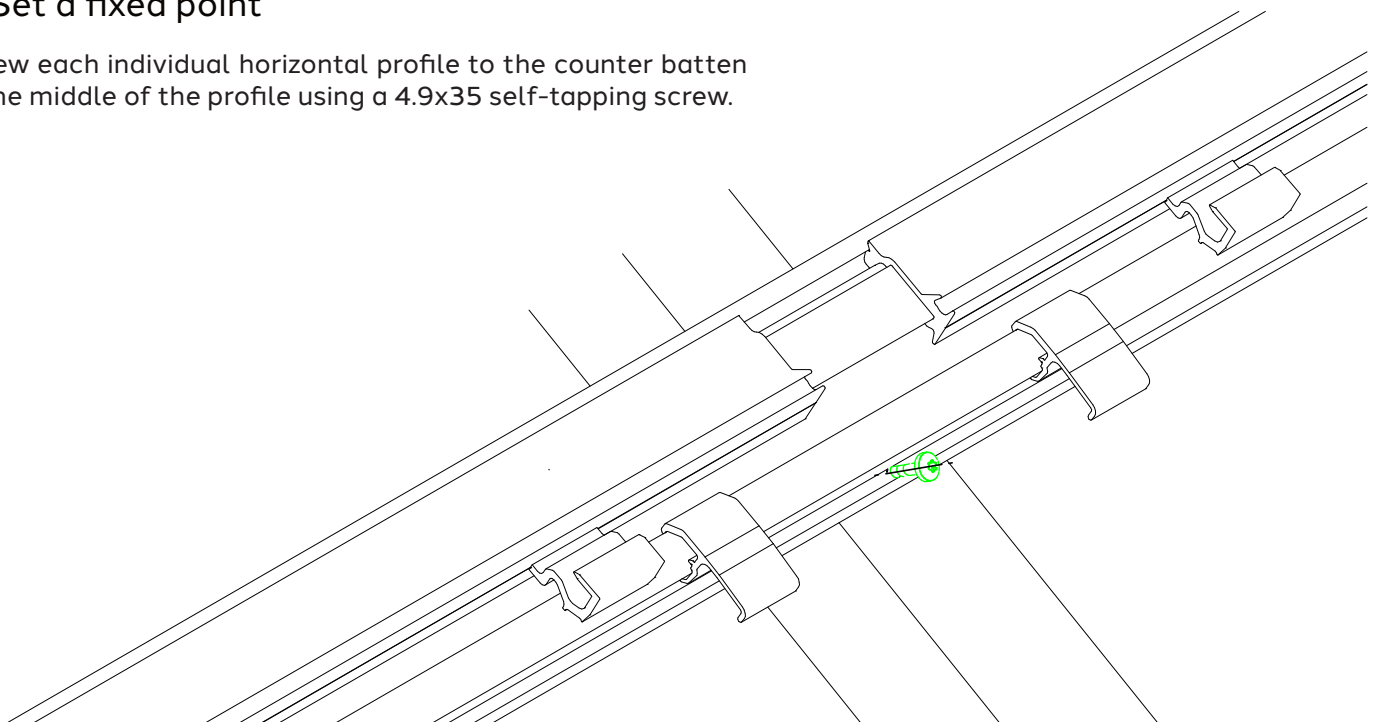

## 2.3 Positioning additional horizontal profile rows with spacer gauge

- Ensure vertical spacing of the horizontal profile using spacer gauges. To do this, insert the spacer gauges into the grooves of the horizontal profile, which are also used for the mounting brackets (see also 2.2.4).

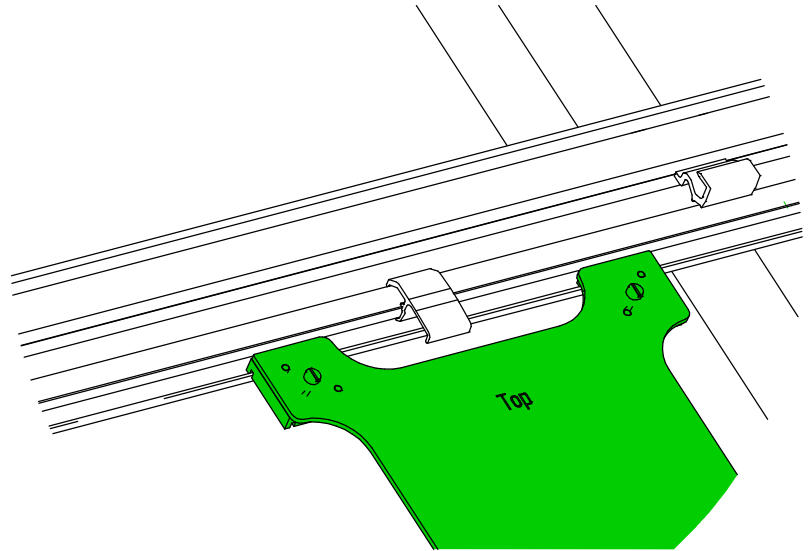

Distance gauges are available for the following grids:

- S/M combined with snow guard
- L combined with snow guard

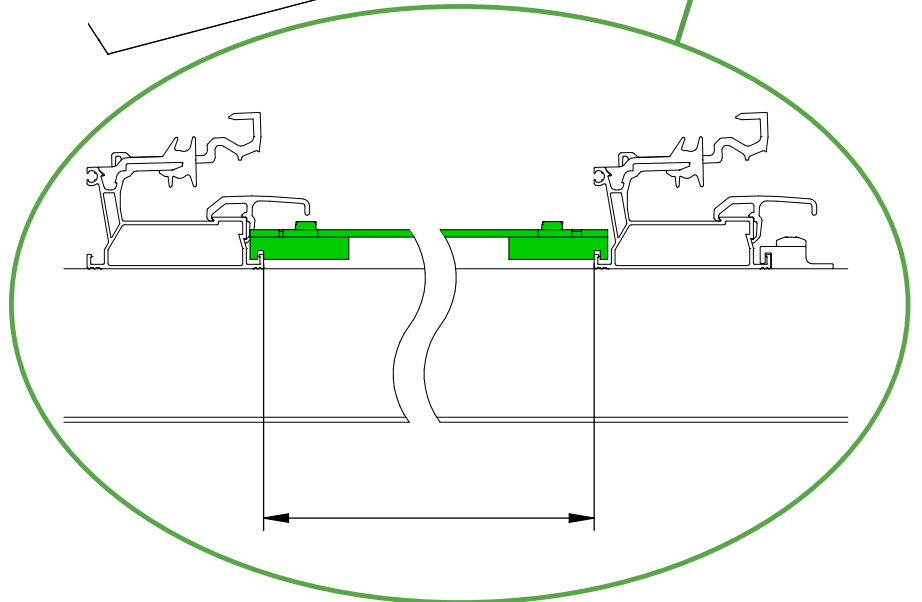
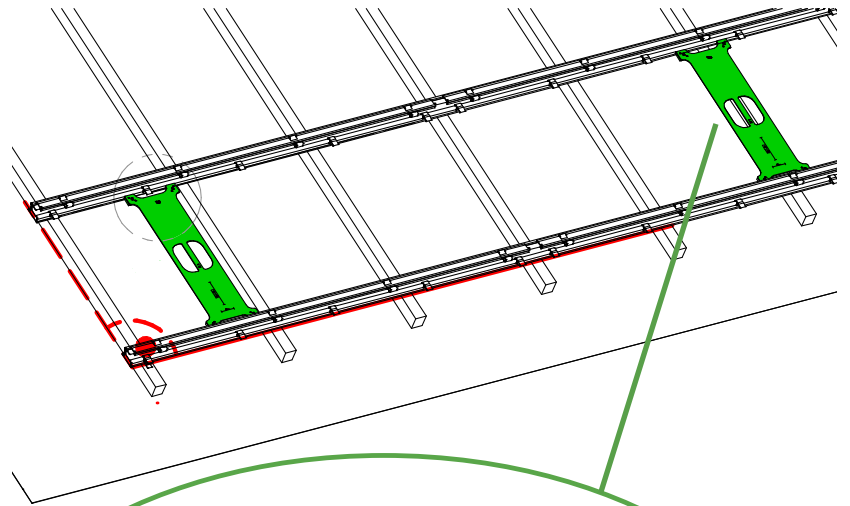

## 2.4 Mounting end profile

- Cut the profile to the required length

For support, see planning documents (regarding situation, min. distances and more) in the appendix.

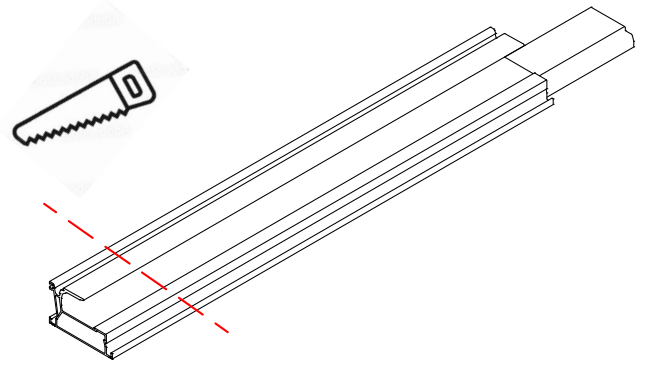

- Insert the end profile into the horizontal profile as far as it will go and fix it to the horizontal profile with the 4.9x35 self-tapping screw.

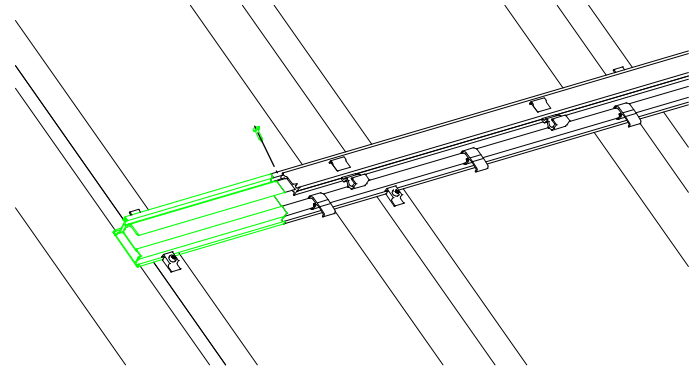

- Cut the seal (2) to length - see illustration and table below for dimensions.
- Cut the seal (2) evenly using pliers or a cutter and thread the module holder (3) into the recesses.

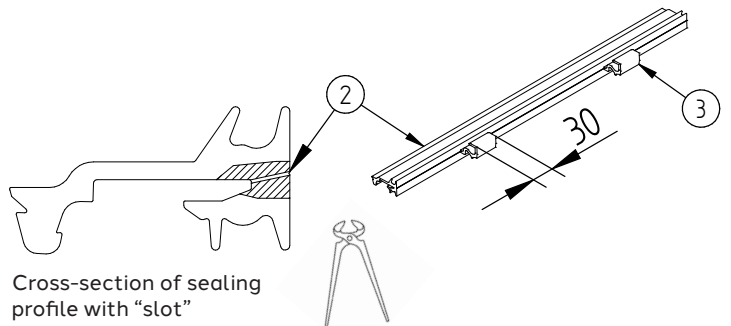

- Fit seal (2) with module holders (3) and support clips (4).
- => Number of support clips = number of module holders + 1

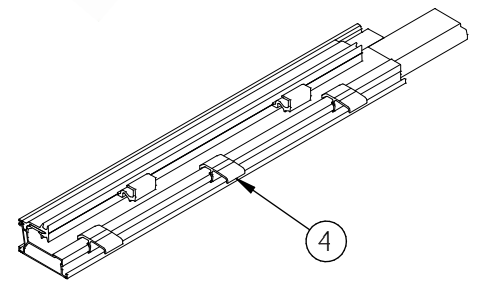

Connection type	X
End & side finish with SOLTOP profiles	23mm
End & side finish with blind modules	0mm
On-site & lateral termination	60mm

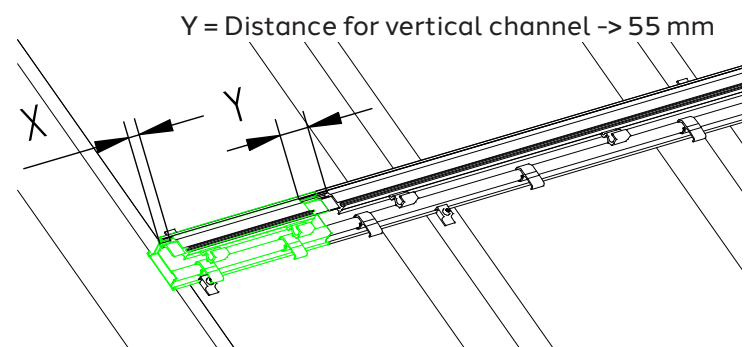

## 2.5 Installation of support slats

Please note in general:

- The screw head must be countersunk to prevent damage to modules!

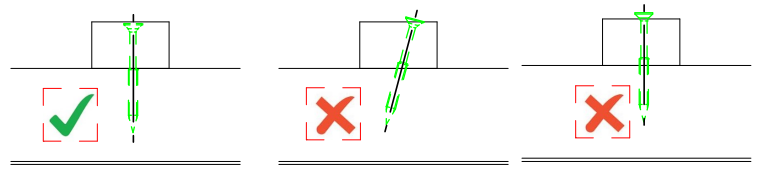

### 2.5.1

#### For S/M grid:

- Fasten the 30x50 support batten at a distance of 310 mm from the lower horizontal profile using screws.
- Check the evenness with the vertical channel (see 2.9). Max. Distance 5 mm.

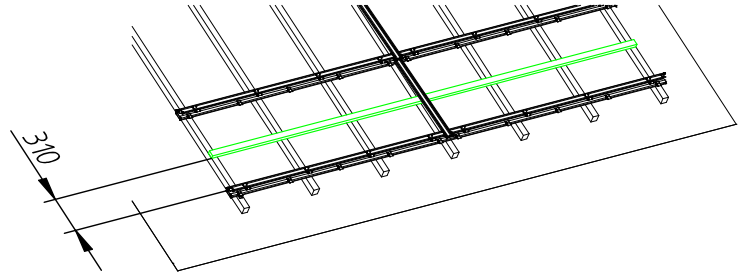

### 2.5.2

#### With L Raster:

- Fasten the 30x50 support slat at a distance of 330 mm from the lower horizontal profile using screws. Second support slat 24x48 required: see structural analysis report.
- Distance: 330 mm
- Check evenness with vertical channel (see 2.9). Max. Max. distance 7 mm.

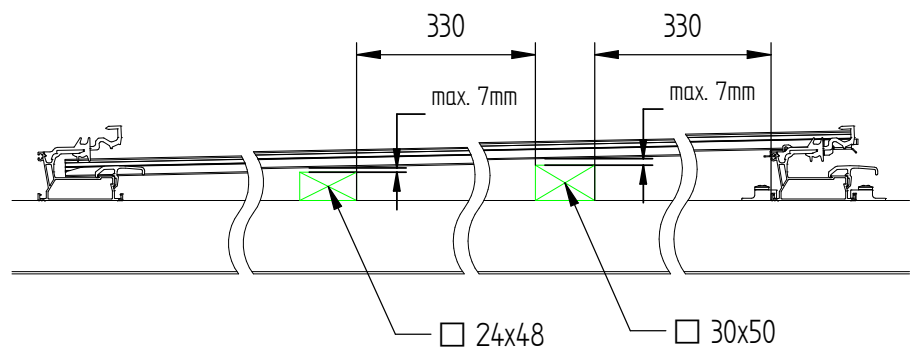
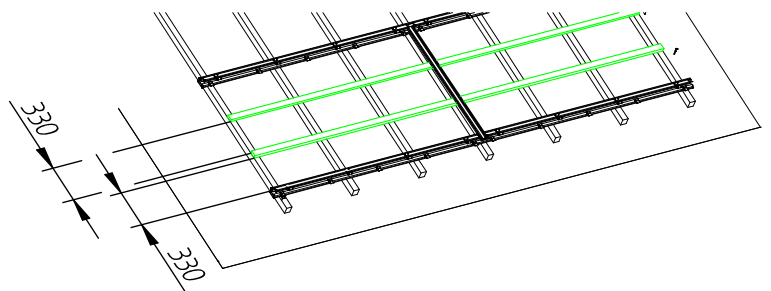
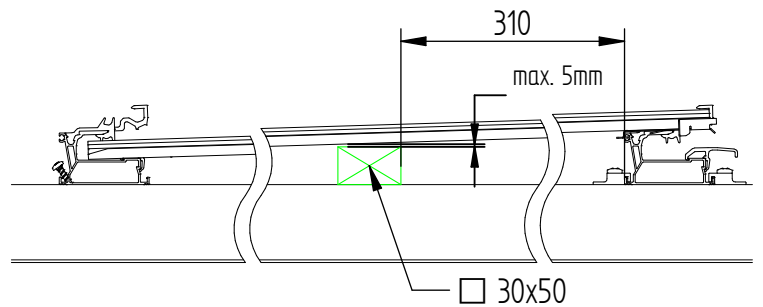

## 2.6 Preparation for tinsmith work

### 2.6.1

Dealing with interfering surfaces (e.g. chimney).  
Install vertical channels next to interfering surfaces.

**1** Cut away 60 mm of the seal on the lower horizontal profile.

**A** The vertical channel must rest completely flat on the horizontal profiles.

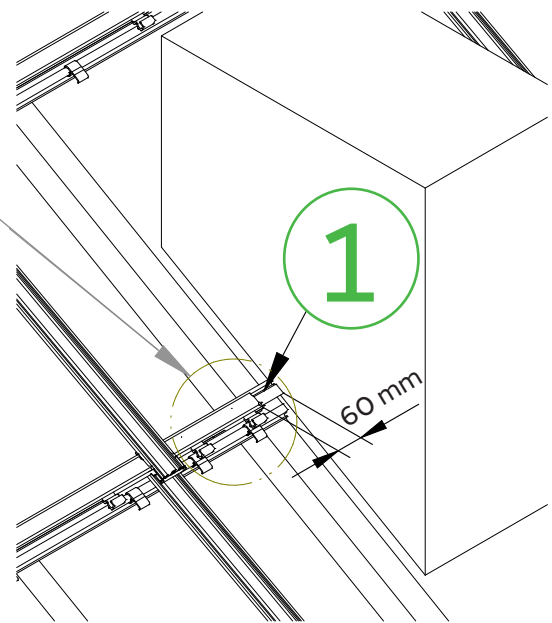
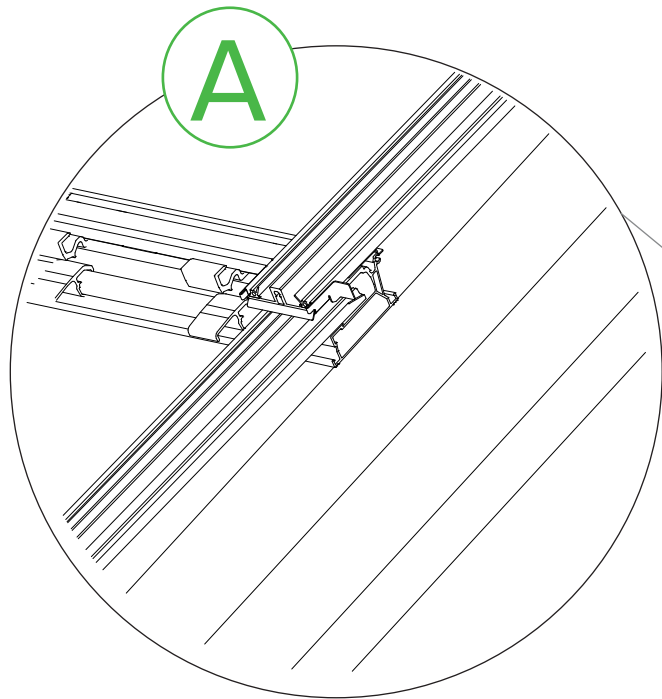
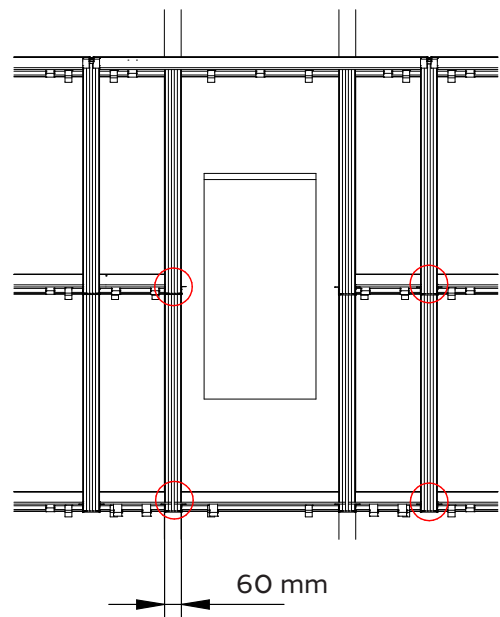

## 2.7 Tinsmith work

### 2.7.1

See planning documents for tinsmith details.

**B** Once the tinsmith sheets have been fitted, pre-drill the stop profiles for sheet metal connections (d=4mm) and then fix them in place with 4.8x13 self-tapping screws.

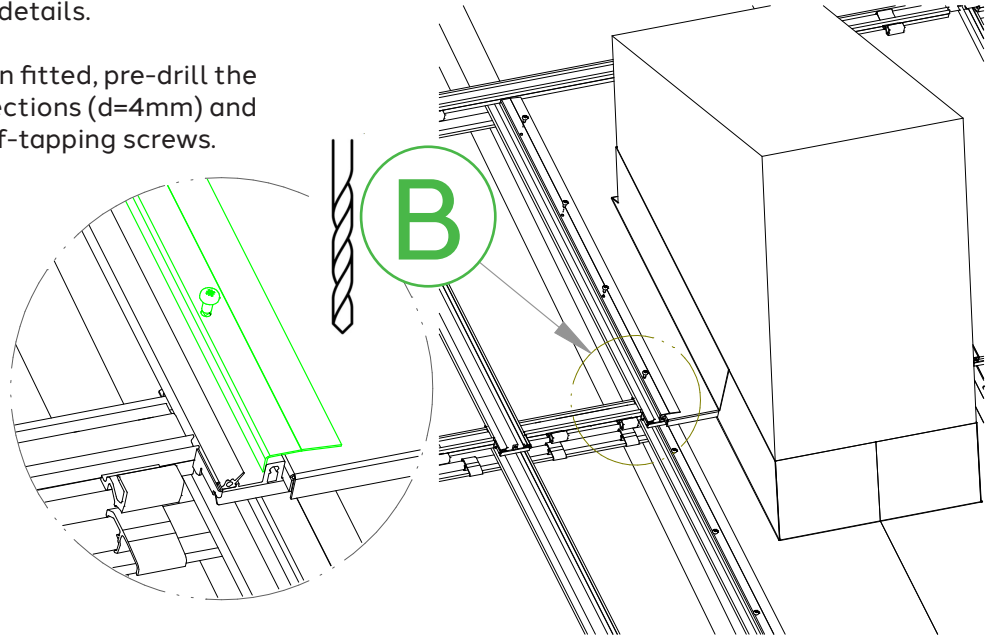

## 2.8 Potential equalization

To connect the horizontal profile rows to each other electrically, they are connected using the equipotential bonding cable set supplied.

- Module field width < 20m connect 1 x
- Module field width 20m - 40m connect 2 x
- Module field width >40m - 60m connect 3 x, etc.

The connection to the equipotential bonding or lightning protection of the building must be made in accordance with NIN 7.12.

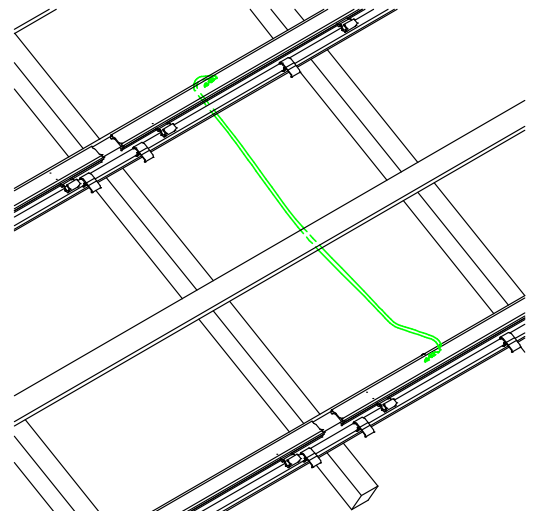
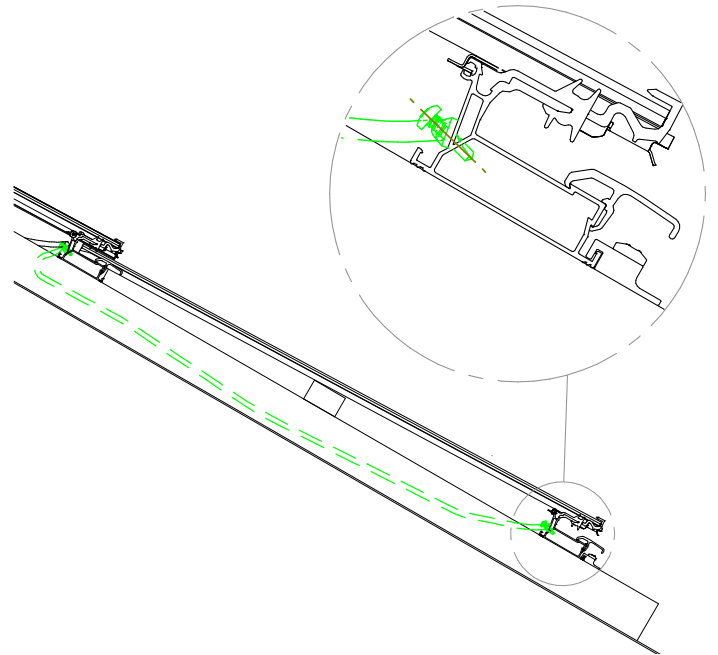

## 2.9 Mounting vertical channel

- Insert the vertical channel into the upper horizontal profile, pull it slightly downwards over the sealing profile of the lower horizontal profile, push it back so that the vertical channel rests and engages in the channel of the lower horizontal profile.

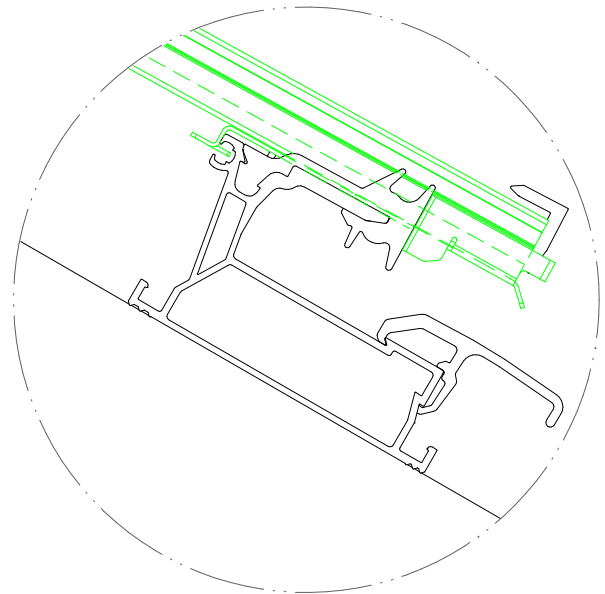
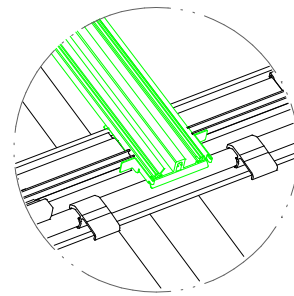
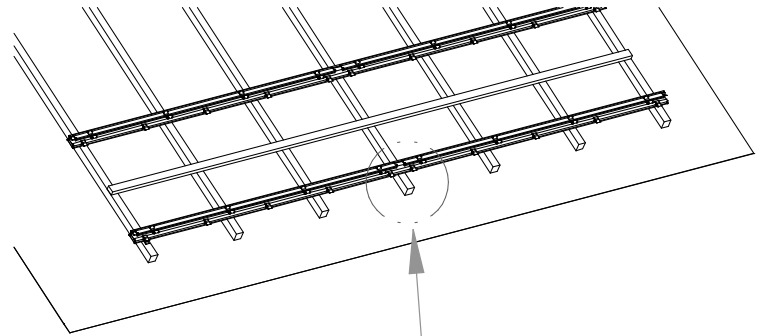
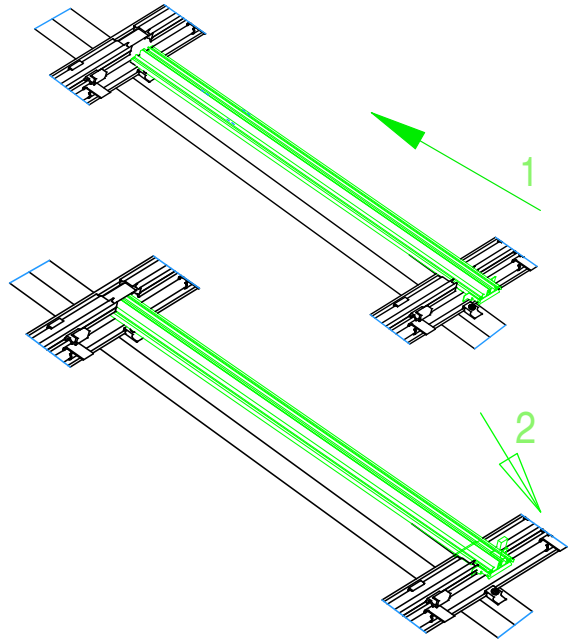

## 2.10 Assembly of in-situ or side closure

- Insert the end caps in the same way as the vertical channel and fix them laterally in the horizontal profile using a 4.8x19 self-tapping screw.

**A** In addition, the tinsmith's sheet must be inserted in advance for side closures (see also planning documents).

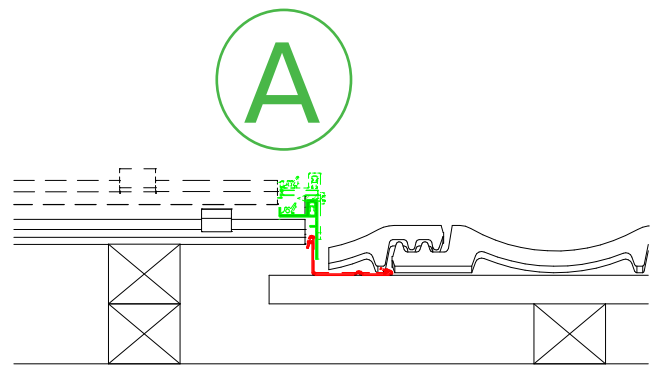
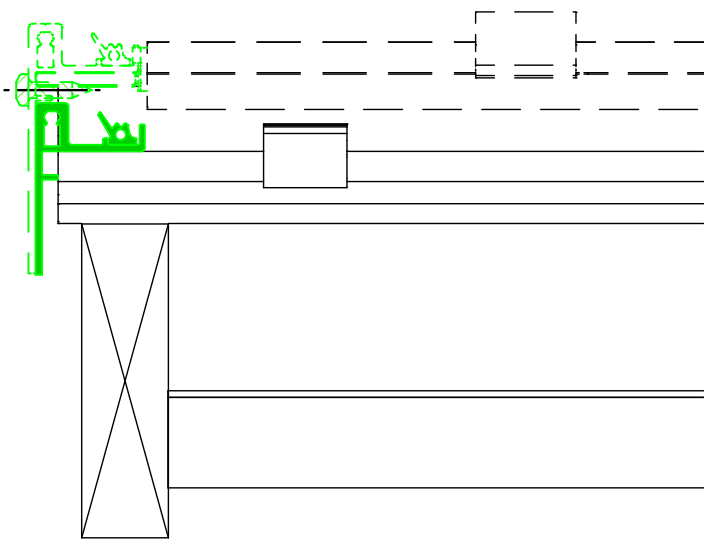
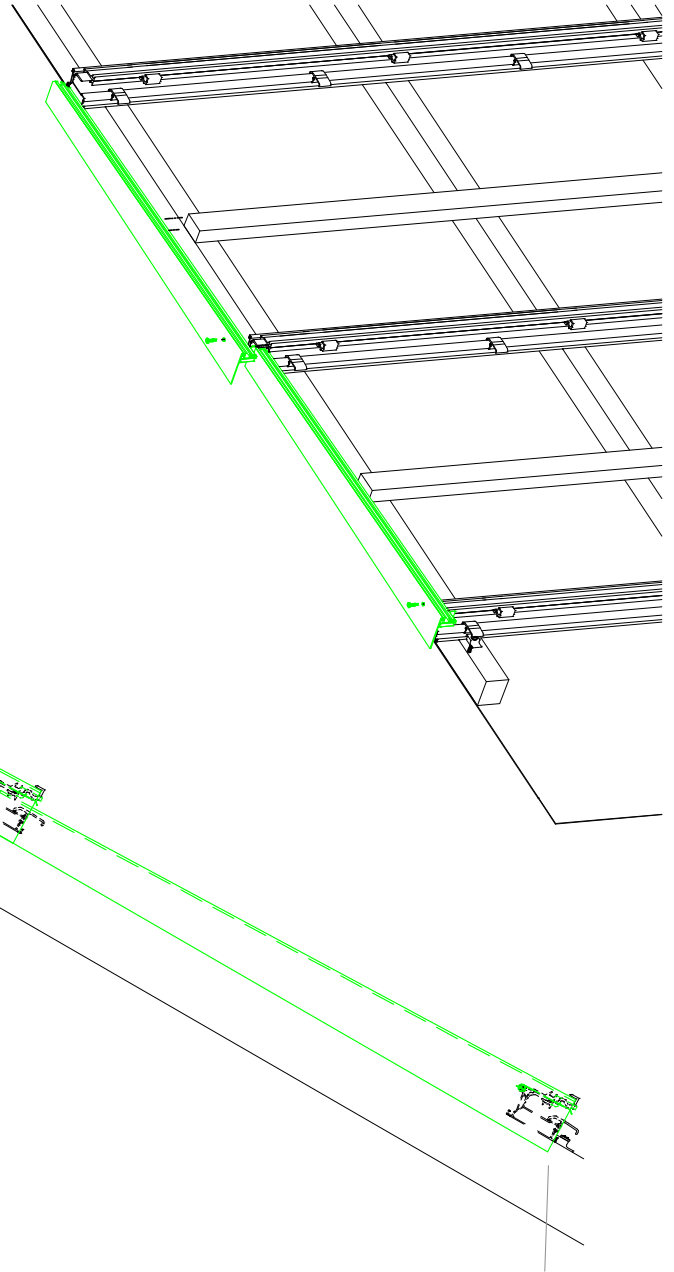

## 2.11 Assembly of sealing profile pieces

- Install 60 mm sealing profile pieces wherever the seal is interrupted and no vertical gutter is installed (ridge, hip roof & others).

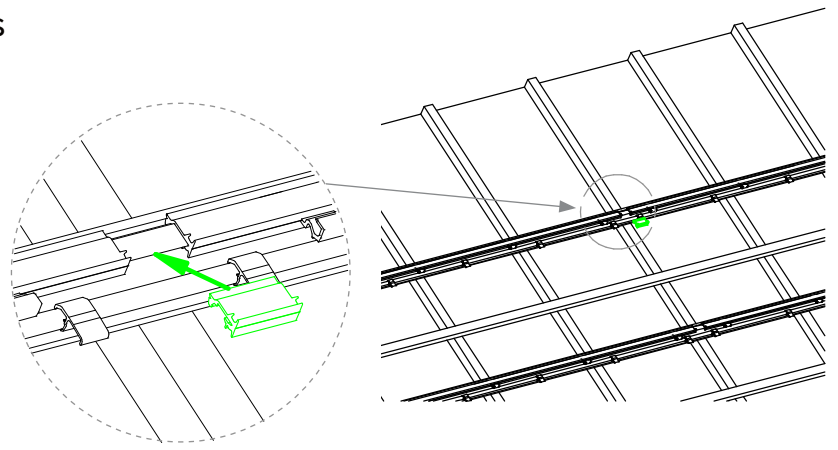

## 2.12 Mounting modules

- All tinsmith work on the roof surface must be completed before the modules are installed.

### 2.12.1 Insert modules

- The modules can be inserted from the left or right, starting with the top row.
- Before inserting the modules, the adjacent modules or the module and the pre-assembled string cable must be connected. The plugs and sockets must be clean and dry.
- Plug in completely until an audible click is heard. The module cable must be routed under the support slat; no cable must be trapped between the module and the support slat.

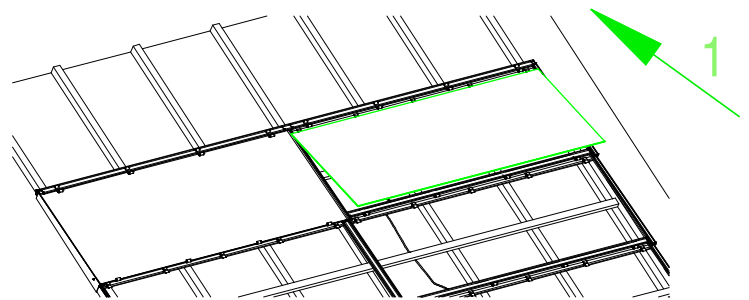
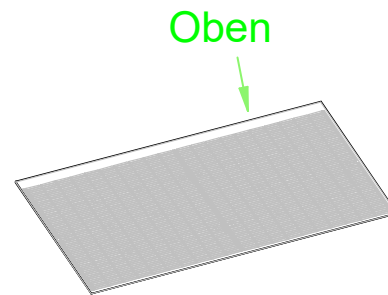

### ATTENTION:

- Insert modules with a wide glass edge at the top.
- Position modules at max. 15° when inserting.
- Carefully pull the module down with the glass suction cup as far as it will go in the module holder.

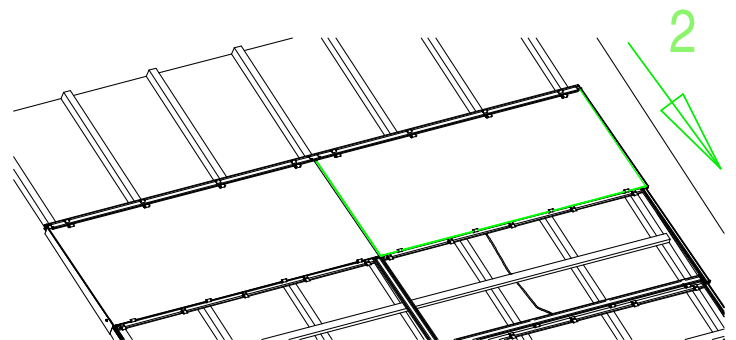

## 2.13 Dummy modules

### 2.13.1 Cutting blind modules to size

- Measure between the two vertical channels and subtract 5 mm.

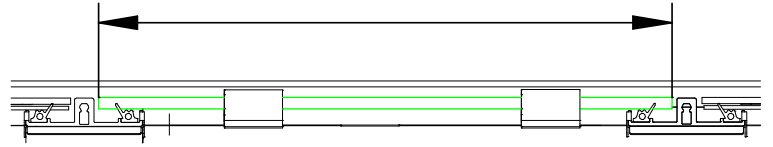

### 2.13.2 Inserting dummy modules

=> Analog 2.12 Insert modules

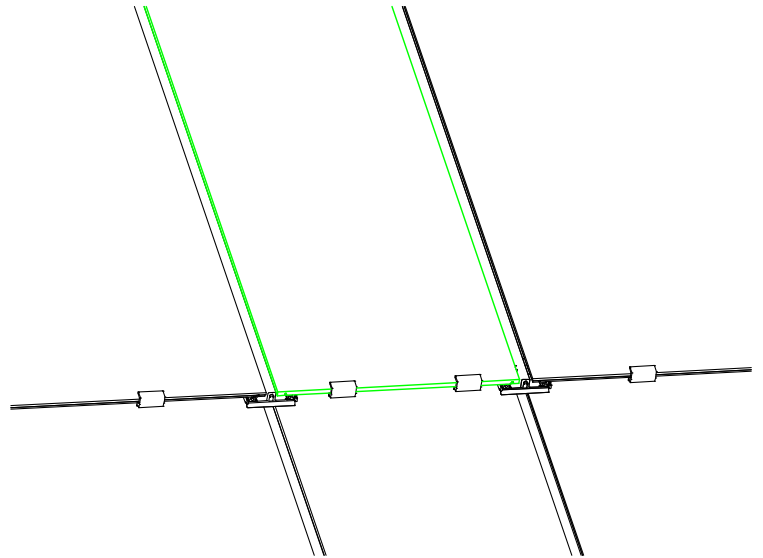

### 2.13.3 Assembly of in-situ or side closure with dummy modules

=> Analog 2.10 Installation of in-situ or side termination

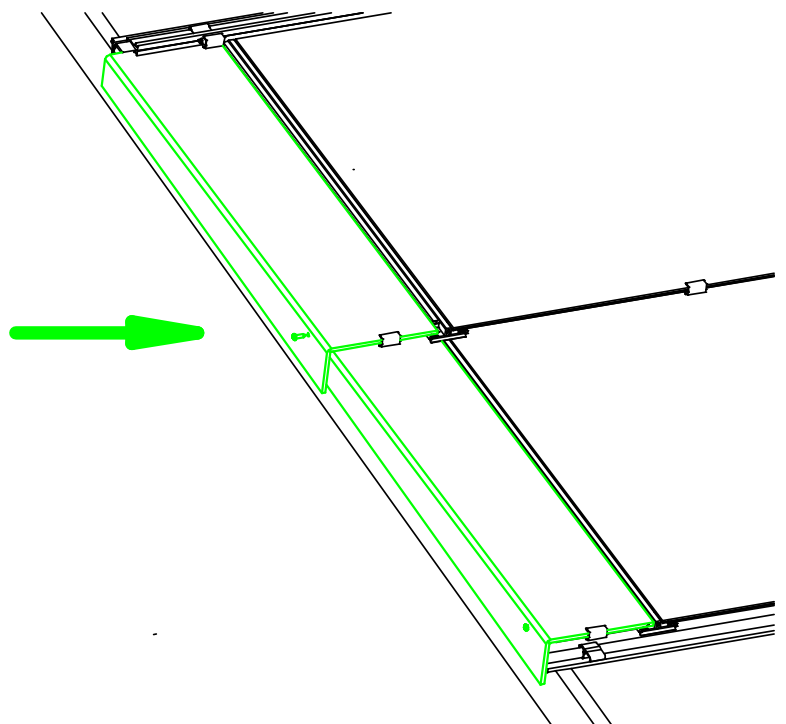

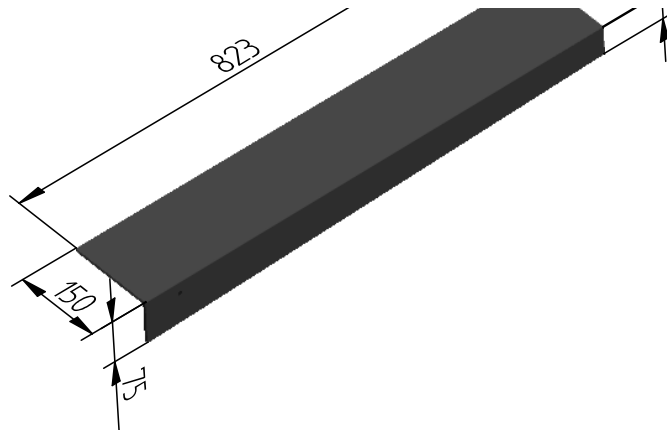

End cap 150 mm right

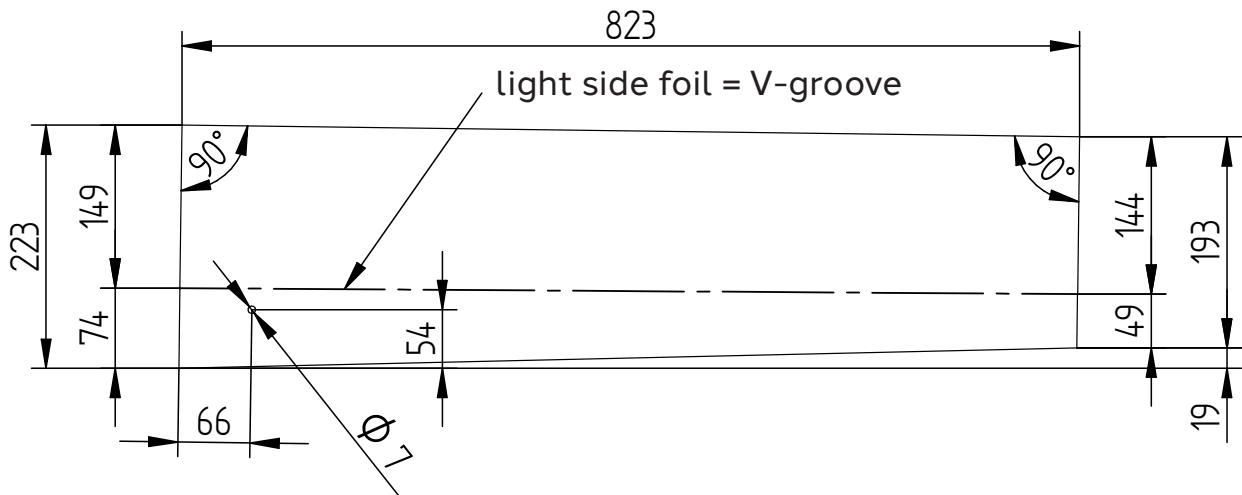

End cap 150 mm left

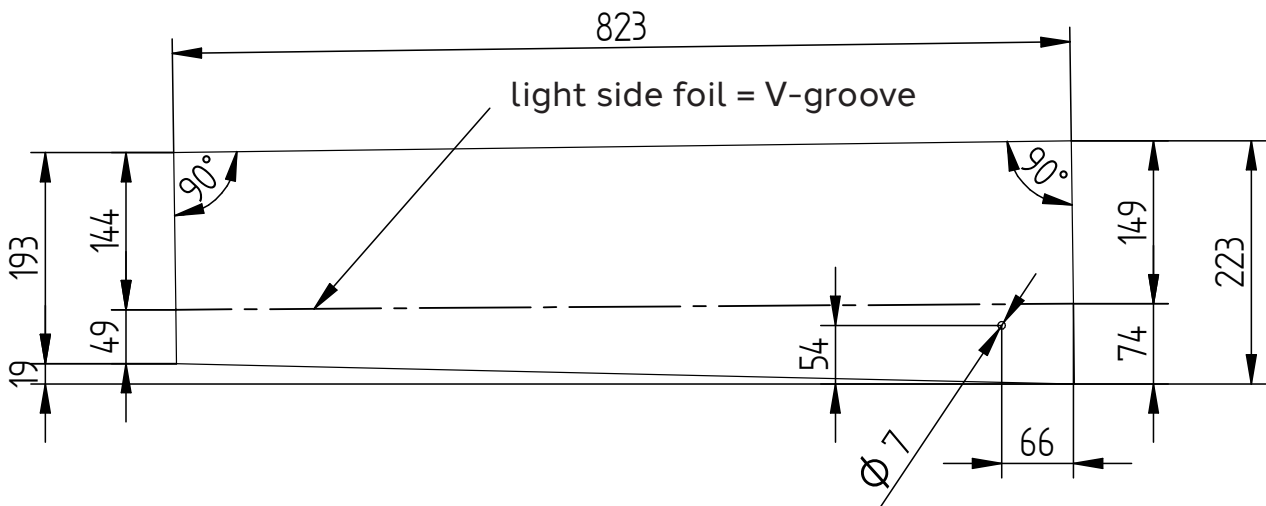

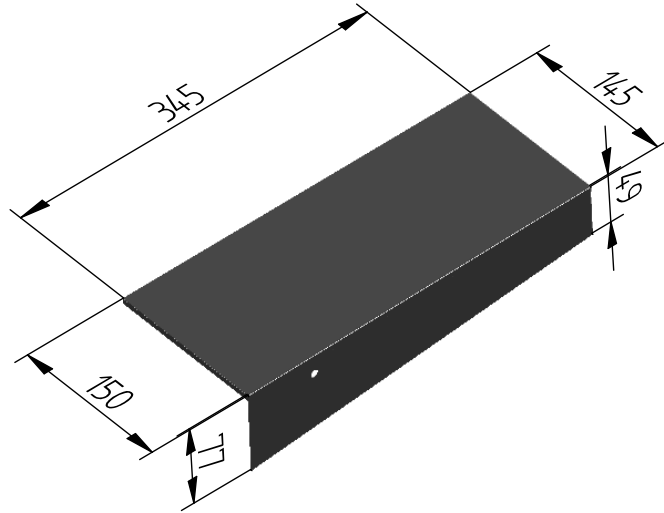

End cap 150 mm right

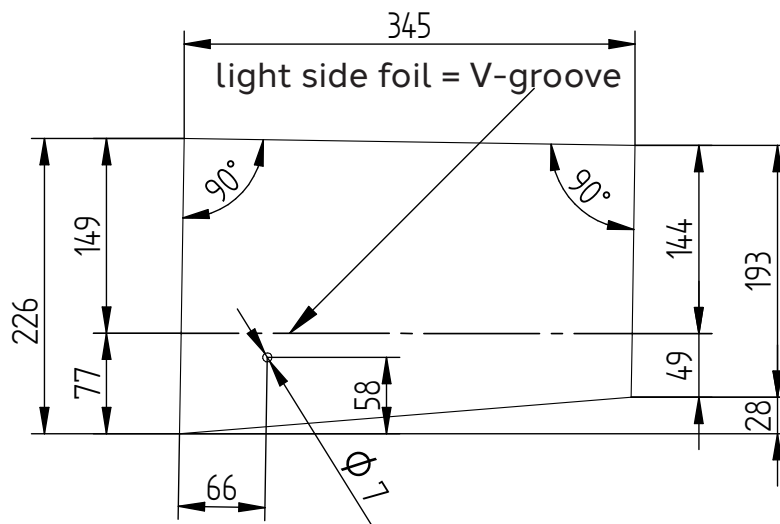

End cap 150 mm left

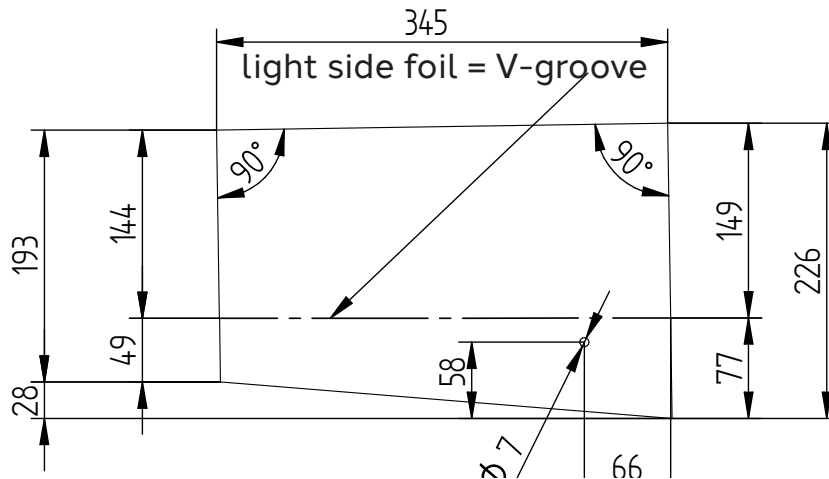

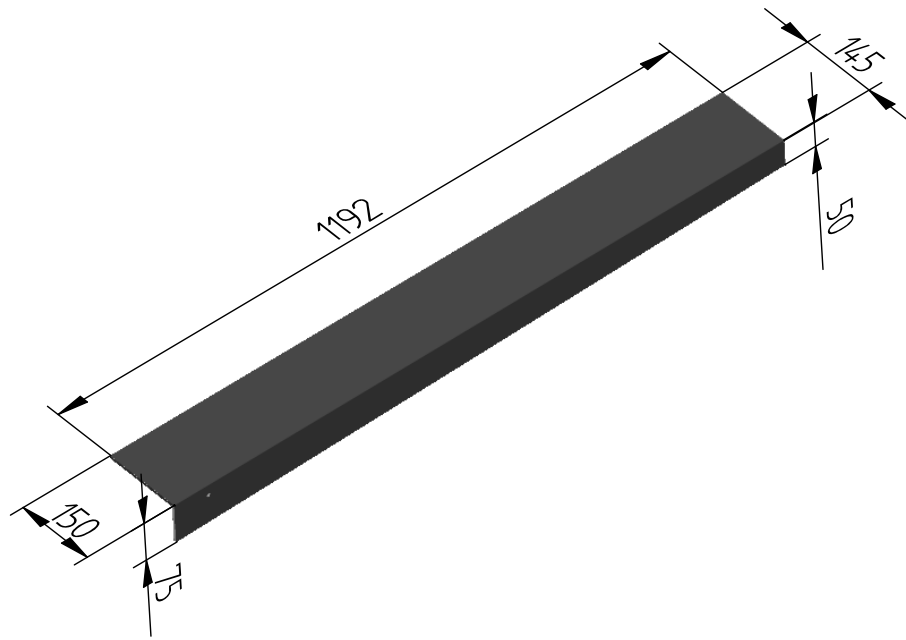
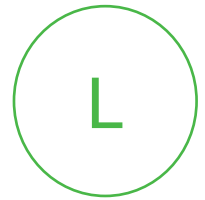

End cap 150 mm right

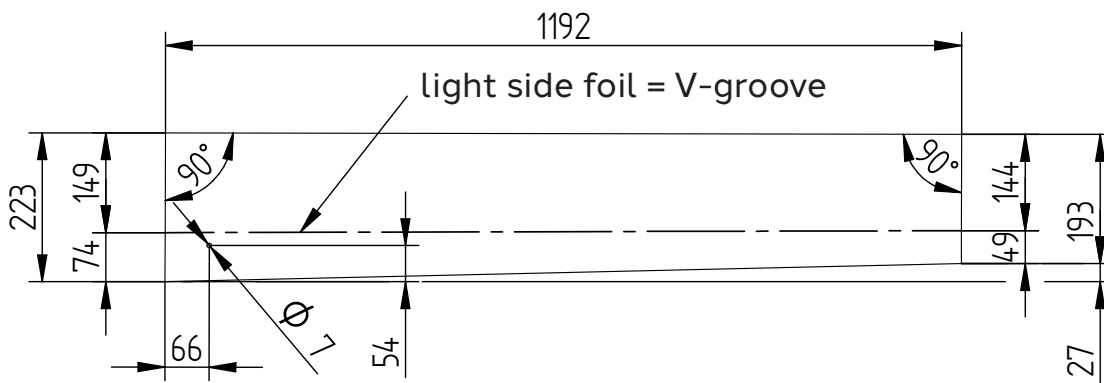

End cap 150 mm left

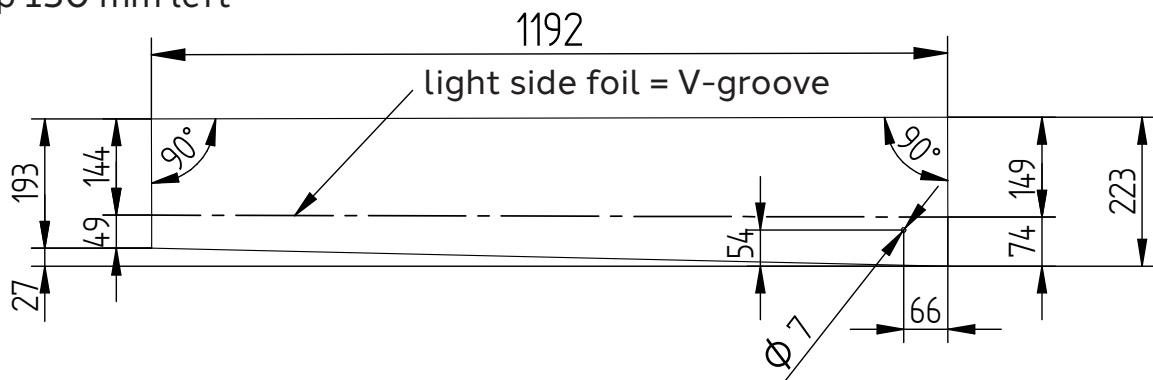

# Attachment B

## Details for complete roof covering (PV only)

Ridge detail with ridge plate

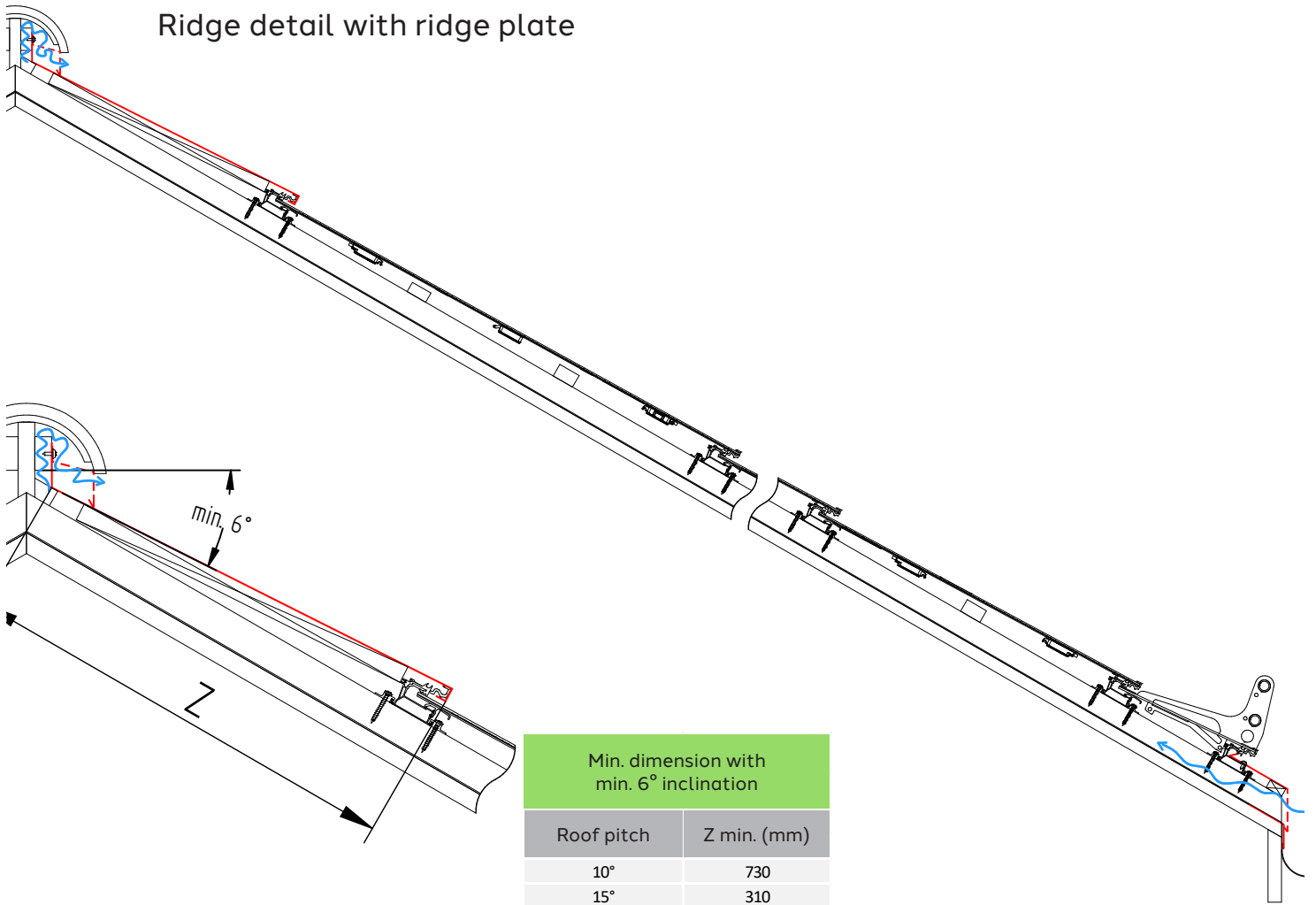

Min. dimension with min. 6° inclination	
Roof pitch	Z min. (mm)
10°	730
15°	310
20°	190
25°	130
≥30°	120

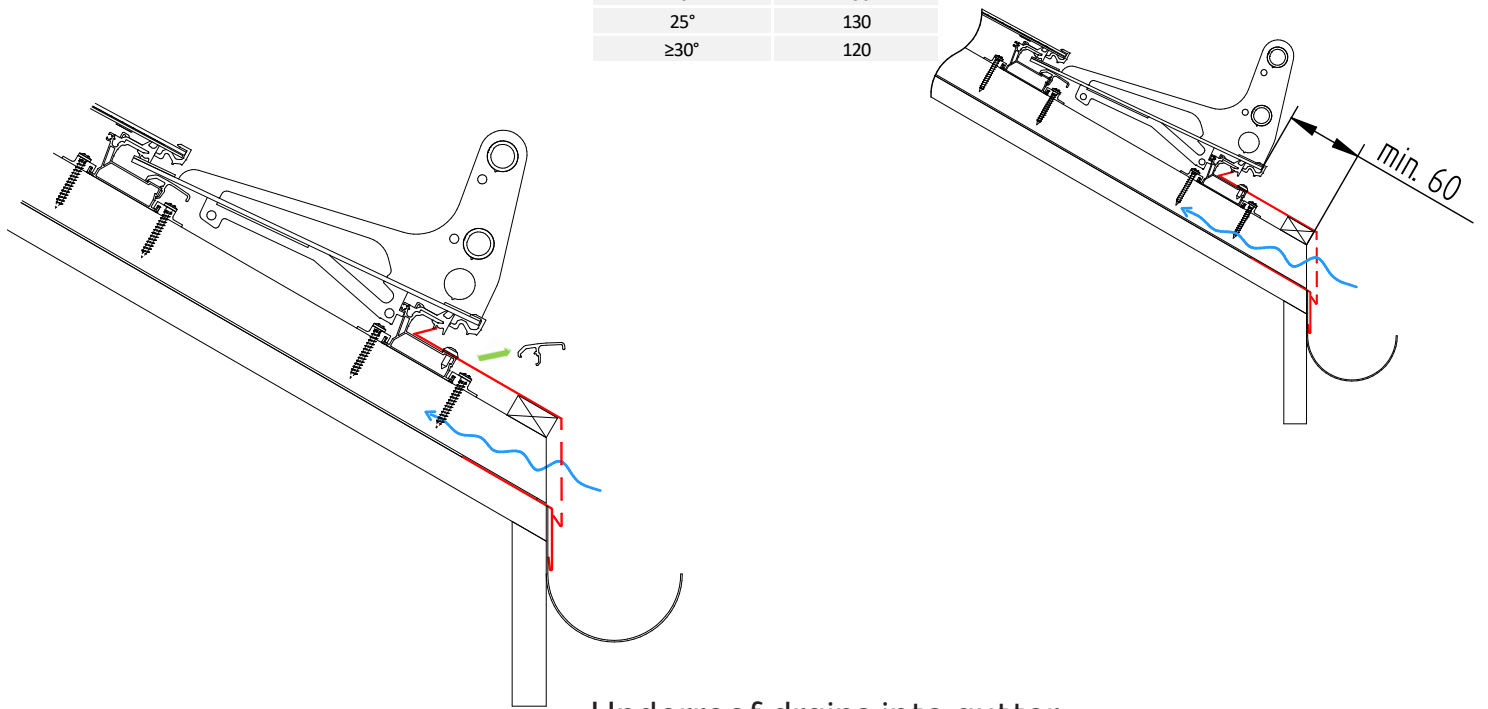

Underroof drains into gutter

Attachment B  
Details for finish in brick

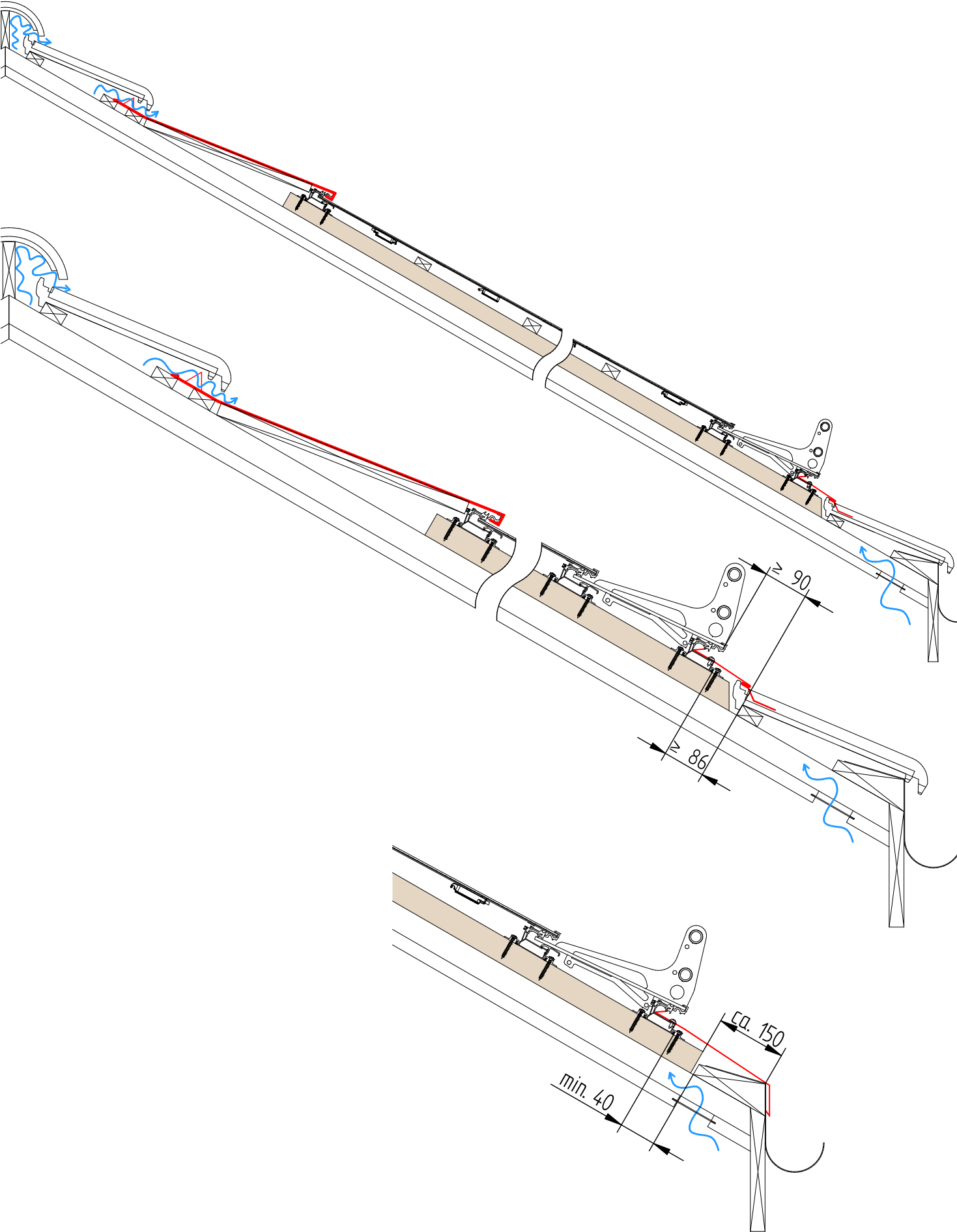

## Attachment B

### Details for finish in brick

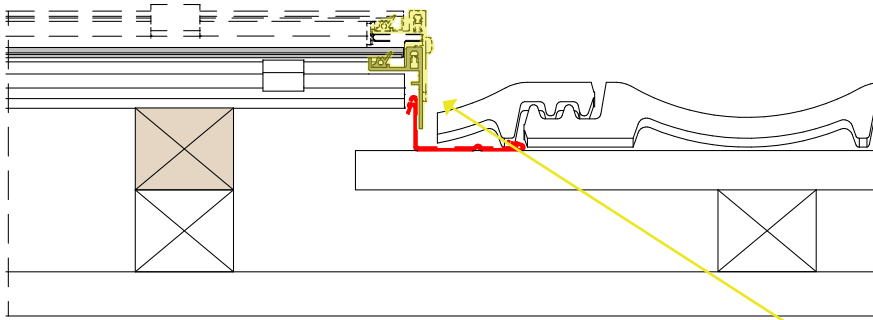

Side closure with SOLTOP profiles

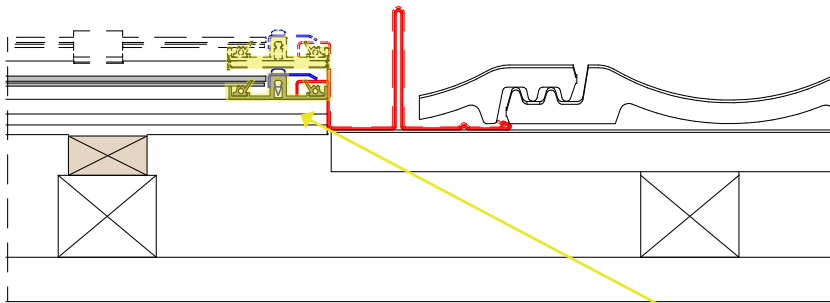

Side finish on site

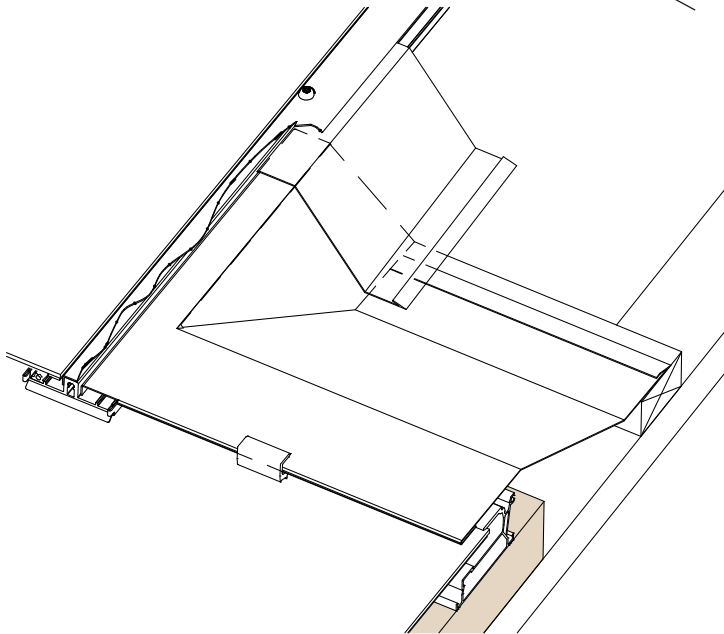

Inside corner Connection to brick

Attachment B  
Bend & location details

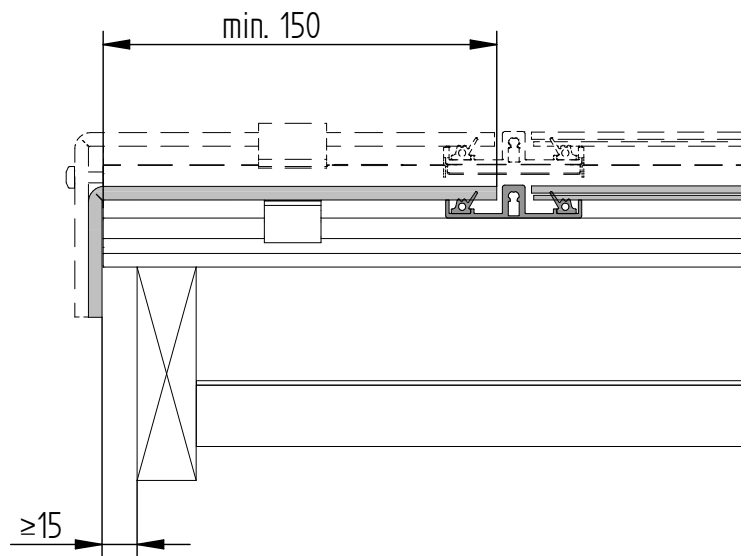
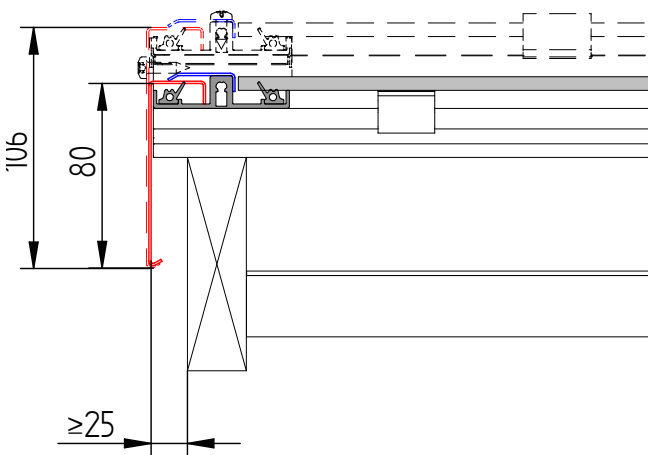
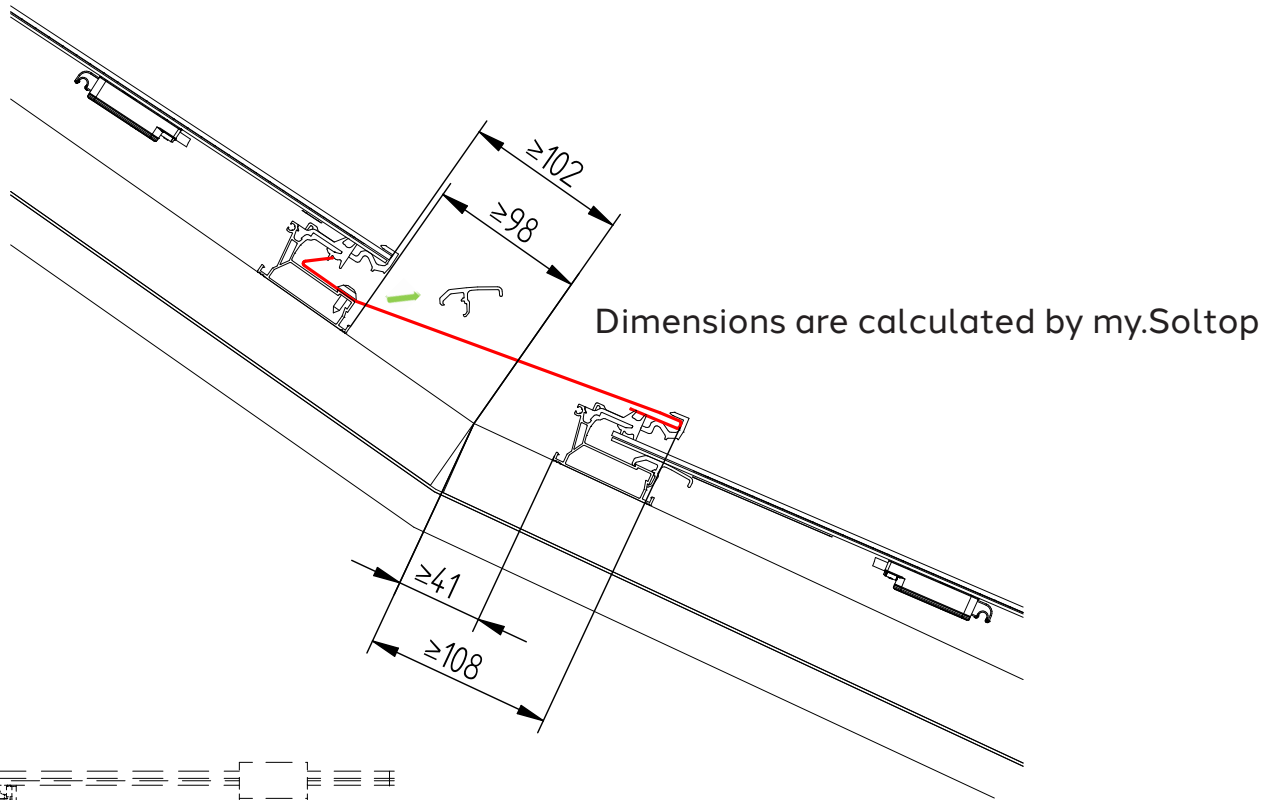

Attachment B  
Ridge details

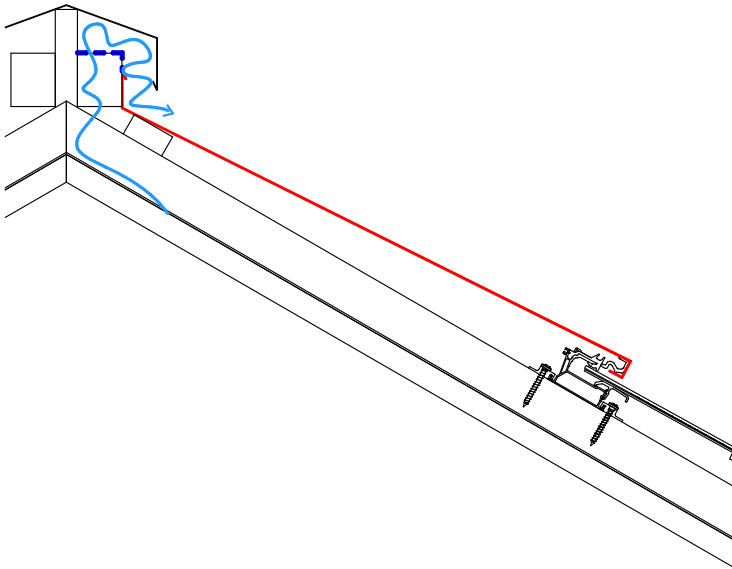

Ridge detail with ridge plate

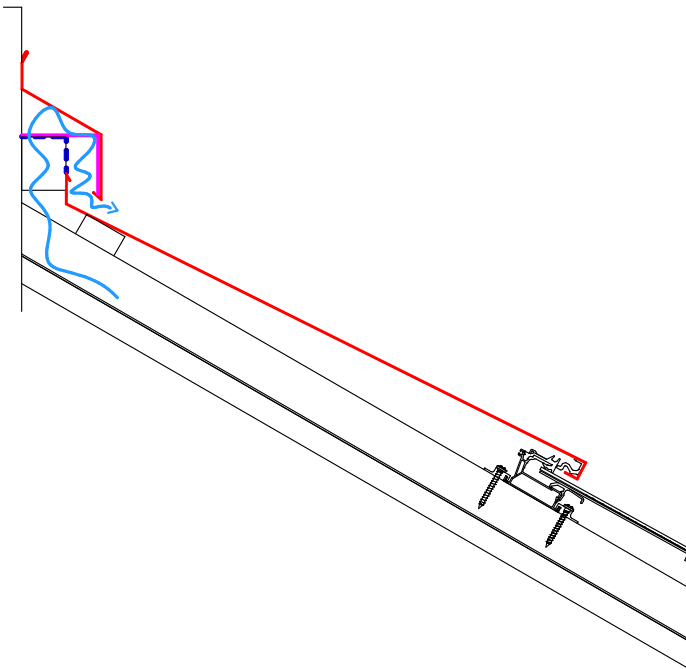

Wall connection

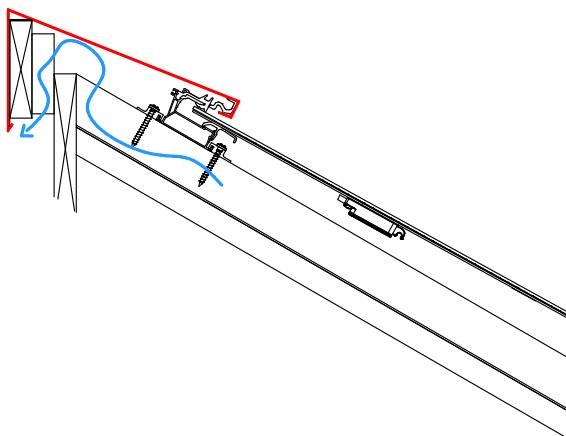

Pitched roof vented

Attachment B  
Chimney

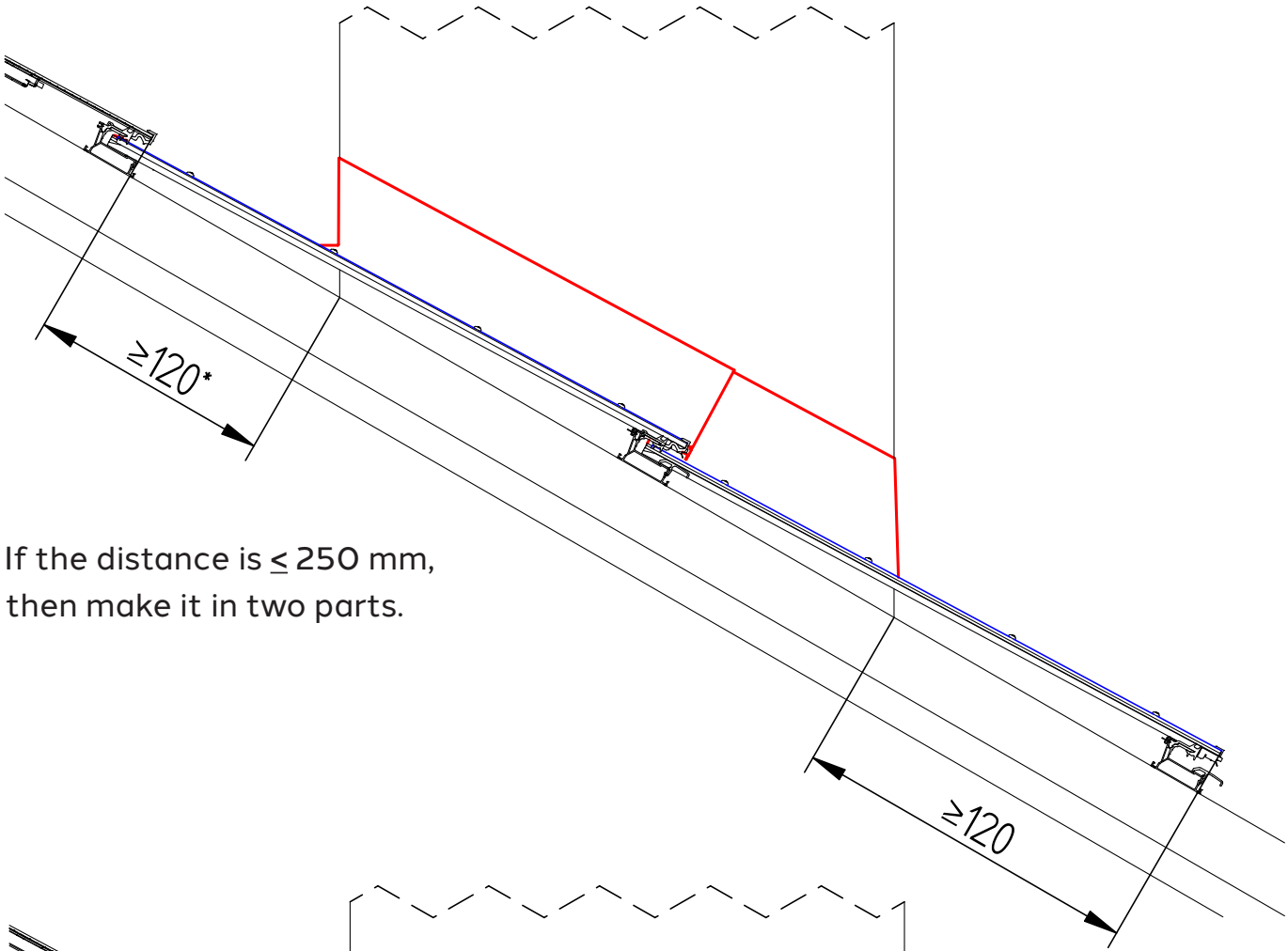

\* If the distance is  $\leq 250$  mm,  
then make it in two parts.

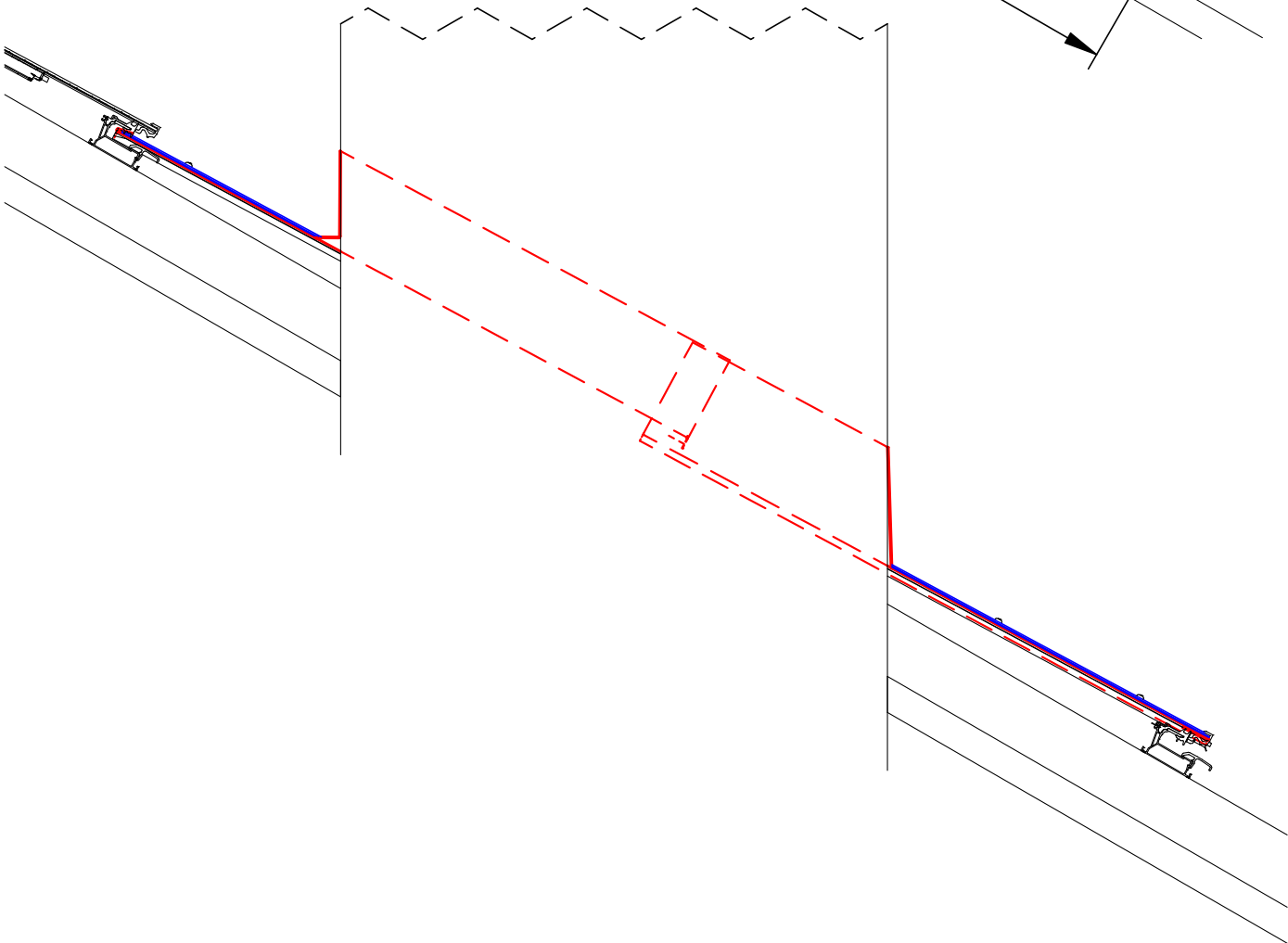

Attachment B  
Chimney

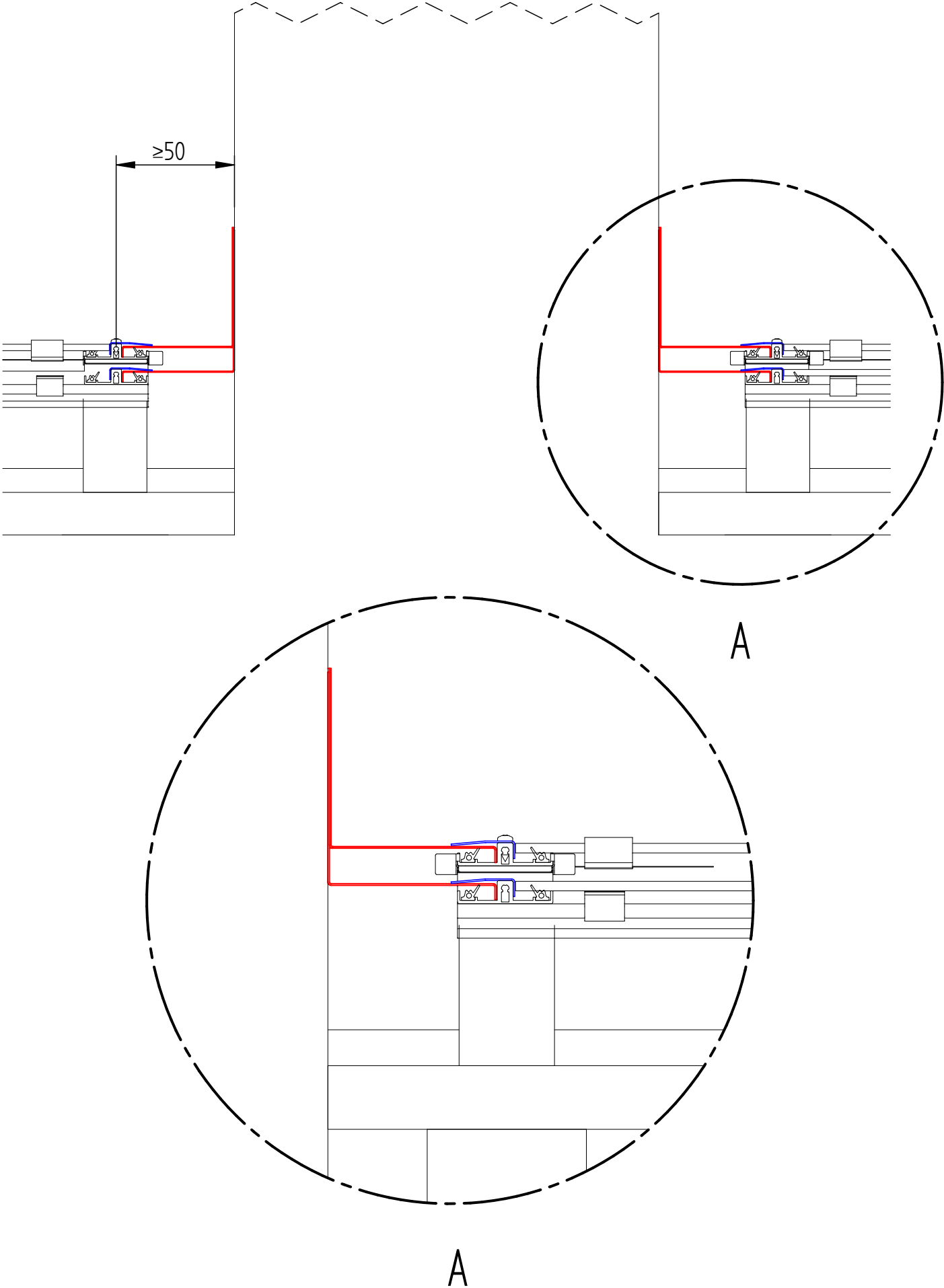

Attachment B  
Velux windows

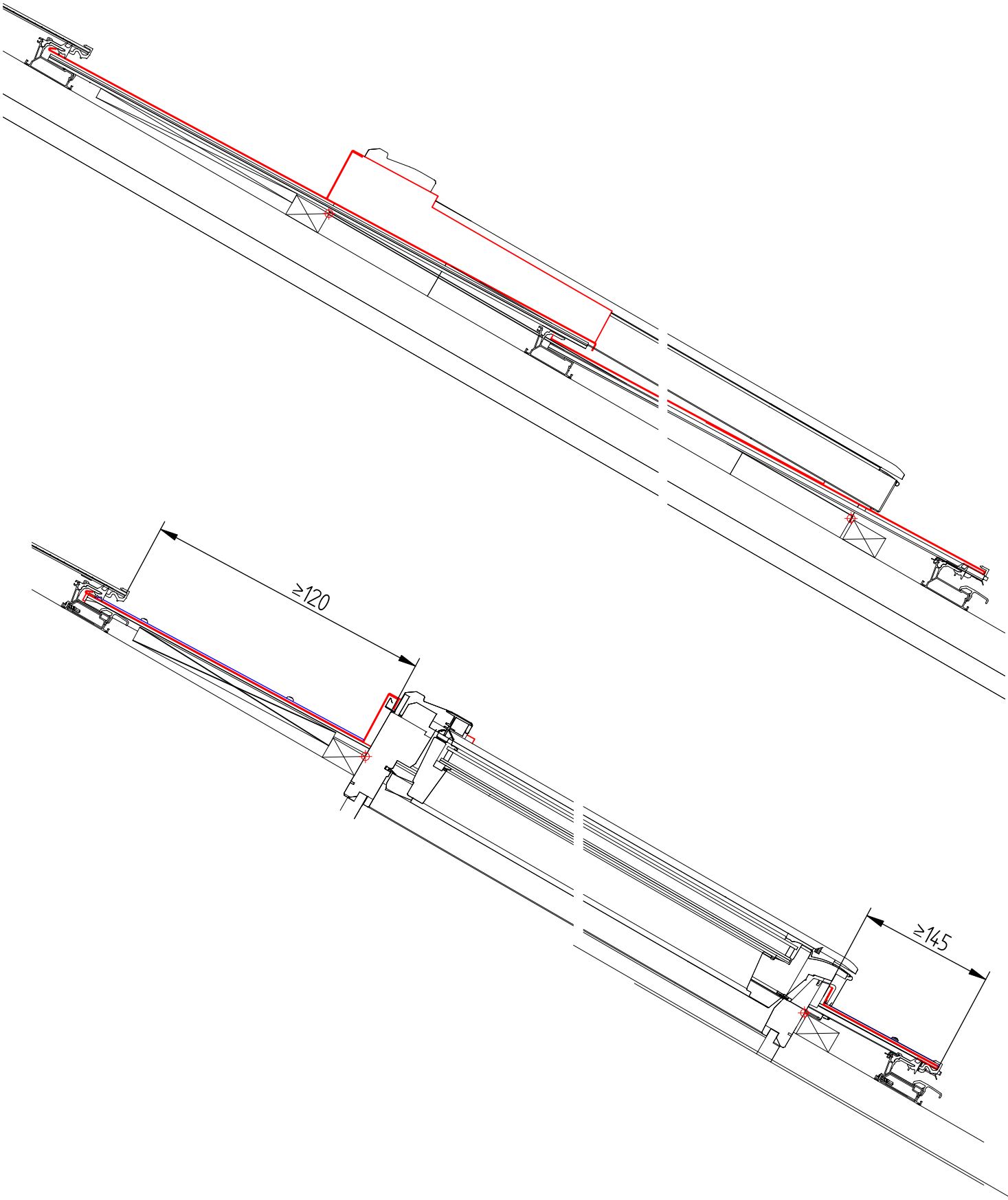

Attachment B  
Velux windows

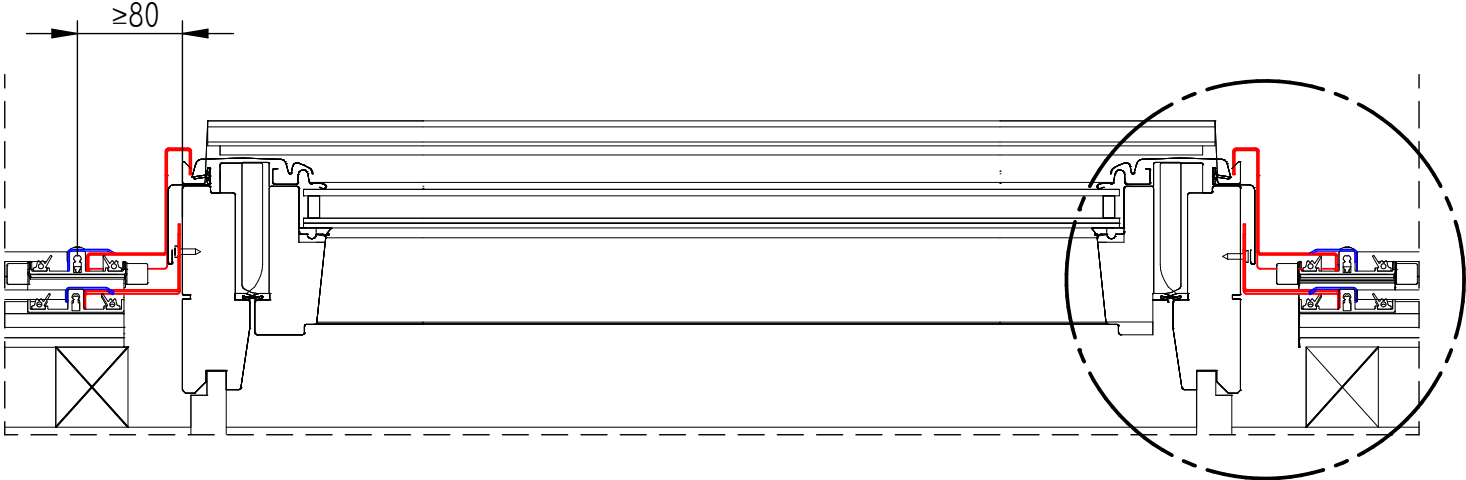

A

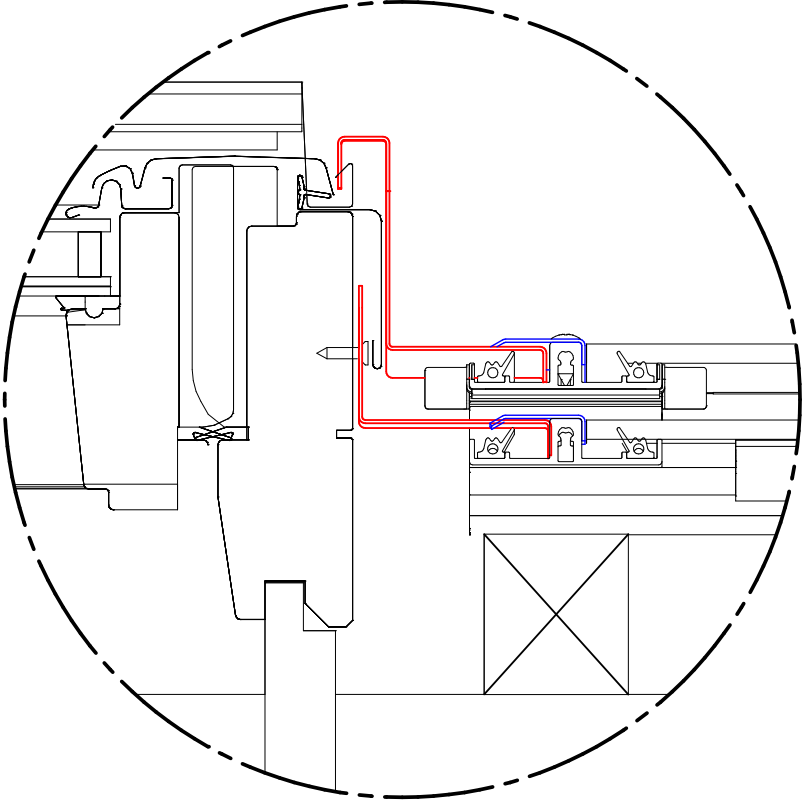

A



Smart technology  
for the energy revolution

**Thank you for choosing a SOLTOP system!**

If you have any suggestions, questions or ideas for improvement, please do not hesitate to contact us:

You can find all contact details at: [www.soltop-energie.ch/kontakt](http://www.soltop-energie.ch/kontakt)

SOLTOP Energie AG  
St.Gallerstrasse 3  
CH-8353 Elgg  
T +41 52 397 77 77  
[info@soltop-energie.ch](mailto:info@soltop-energie.ch)

SOLTOP Energie SA  
Rue des Sablons 8  
CH-3960 Sierre  
T +41 27 451 13 20  
[info.fr@soltop-energie.ch](mailto:info.fr@soltop-energie.ch)

SOLTOP Energie SA  
Avenue Haldimand 41  
1400 Yverdon-les-Bains  
T +41 21 946 30 31  
[info.fr@soltop-energie.ch](mailto:info.fr@soltop-energie.ch)

SOLTOP Energie GmbH  
Lindauer Straße 15  
D-88145 Hergatz  
T +49 (0)8385 27899 0  
[info@soltop-energie.eu](mailto:info@soltop-energie.eu)