

Duraklick

A brand of SOLTOP Energie GmbH



Flat Roof System XL

Installation Instructions



Important Information

Scope of the Manual

This installation manual describes exclusively the assembly of the Duraklick XL mounting system for photovoltaic modules. For the installation of other components (inverters, monitoring systems, etc.), please use the documentation provided by the respective manufacturer.

Target Groups

The Duraklick mounting system must only be assembled and commissioned by persons with the professional qualifications (e.g., training or relevant work experience) or experience necessary to ensure correct execution in accordance with regulations.

Documentation Storage

The system operator must ensure that this installation manual is available at all times for maintenance purposes.

Lightning Protection

Lightning protection measures must be planned by the installer in cooperation with the qualified specialists responsible for this area.

Warranty Provisions

The "Warranty Conditions for SOLTOP Energie Products" as well as the "General Terms of Sale" of SOLTOP Energie valid at the time of purchase apply.

Maintenance

Photovoltaic installations are technical systems and require periodic inspections. SOLTOP Energie AG offers corresponding inspection and maintenance services.

Delivery Contents

The delivery must be checked immediately upon receipt for completeness. Any complaints regarding defects can only be made on the day of delivery.

Roof Requirements

- ▶ The roof structure must be capable of supporting the additional loads from the photovoltaic system.
- ▶ The roof covering must have adequate holding capacity for the substructure.
- ▶ Roof slopes from 0° to 5° are allowed.
- ▶ The roof's friction coefficient must be verified on site.

Installation Requirements

- ▶ All instructions in this installation manual must be strictly observed during system installation.
- ▶ Only components supplied by SOLTOP Energie AG may be used for the Duraklick system. Using third-party parts releases SOLTOP Energie from any liability.
- ▶ SOLTOP Energie AG's mounting systems are constantly evolving, so the latest version of the installation manual should always be used. Download: <https://www.soltopenergie.ch/planungsunterlagen>
- ▶ Potential equalization within and between module arrays must comply with national regulations.
- ▶ For continuous base rails, ensure proper water drainage.



Wind Hazard!

In the event of an interruption or stop of the installation, all modules or rows already installed must be secured using wind deflector plates and spoilers.

WARNING: Wind hazard!

Loose rails must be fastened or weighted down



Modules

- ▶ The system is suitable for modules with the following maximum dimensions:
 - Length 2450 mm
 - Width 1200 mm
- ▶ The system is suitable for modules with a frame height of 30 to 40 mm.
- ▶ The torque for the module clamps must be checked in the module manufacturer's installation manual (if no information is provided, use 10 Nm).
- ▶ The clamping range of the module must be checked in the module manufacturer's installation manual.
- ▶ The module manufacturer's installation manual must always be followed.

my.Soltop Design Software

Design:

The planning of the photovoltaic system is carried out using the my.Soltop design software.

If the planning is to be performed by SOLTOP Energie, all relevant planning information must be provided. For a quick and straightforward design, we recommend that all customers use my.Soltop independently. In just a few steps, you can plan your own system and receive a quotation quickly. The information on the output documents is based on the values entered in my.Soltop. All dimensions must be verified on site.

Standards and Safety Regulations

When installing the mounting systems, compliance with the relevant standards and safety regulations must be ensured. In particular, this includes:

Electrical Installation:

- ▶ DIN VDE 0100-712 (IEC 60364-7-712) Low-voltage electrical installations – Part 7-712: Requirements for operating sites, premises, and special installations – Photovoltaic (PV) power supply systems
- ▶ DIN VDE 0126 Solar installations for private use
- ▶ DIN EN 62305 Lightning protection
- ▶ VDEW Directive (2001)
- ▶ VDI 6012, Sheet 2 Decentralized energy systems in buildings – Photovoltaics
- ▶ TAB Technical connection conditions of energy distribution companies

Accident Prevention Instructions:

- ▶ BGV A1 Principles of accident prevention
- ▶ BGV A3 Electrical installations and equipment
- ▶ BGV C22 Construction work
- ▶ BetrSichV, supplemented by "Instructions for the use of ladders and stepladders" (BGI 694)

Others:

- ▶ VDS (Association of Property Insurers) Guidelines
- ▶ DIN EN 1991-1-4 Wind loads
- ▶ DIN EN 1991-1-3 Snow loads
- ▶ DIN 1052 Design, calculation, and dimensioning of timber structures – General design rules and rules for building construction
- ▶ Current local regulations and requirements must be observed

Take Photos of Roof Damage!

Before installation, the roof should be inspected for any damage, particularly water ingress or damage to the roof covering.

Any findings should be documented using a digital camera to prevent any subsequent claims.

Roof Preparation

The roof surface to be covered must be free of debris, such as sharp stones, moss, leaves, dirt, etc., to ensure full support of the base rails. Clean the roof!



Caution

Qualified Personnel!

The installation of modules and the laying of DC wiring must be carried out by qualified personnel. (Risk of electric shock! Risk of electric arcs! etc.) In systems with lightning protection, an integration check must be carried out by certified lightning protection companies. It must also be verified whether the lightning protection requirements are affected or require adjustment due to the installation.

Tip



Photograph Roof Damage!



Clean the roof.



Wear gloves during installation!
Risk of injury from sharp edges!

List of Tools

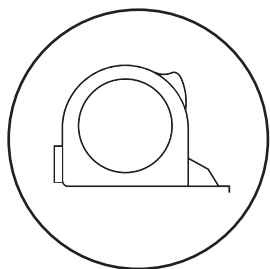

Measuring tape

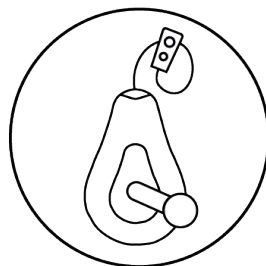

Chalk line

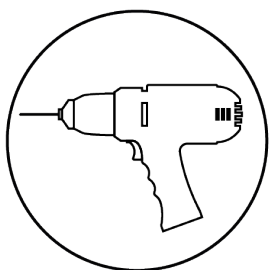

Cordless screwdriver

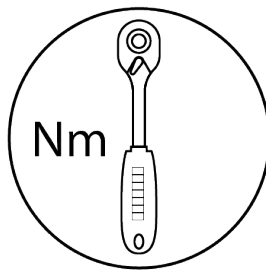

Torque wrench

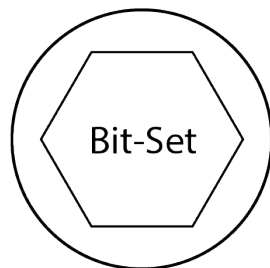

Bit set

1. Components

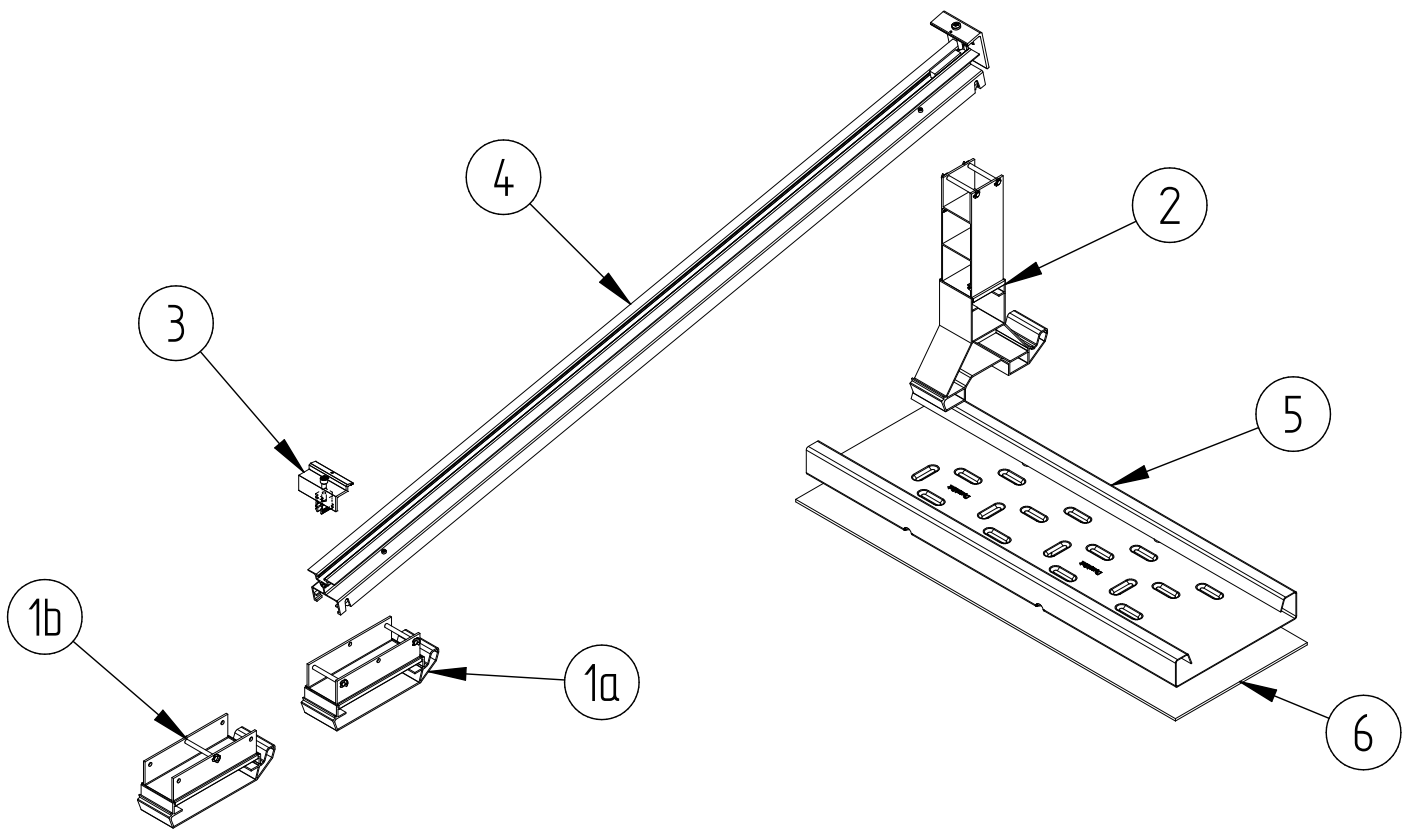

- 1a Duraklick XL Lower Support 12°
- 1b Duraklick XL Lower End Support 12°
- 2 Duraklick XL Upper Support 12°
- 3 Duraklick XL Black End Clamp
Available in the following versions:
Clamp height: 30 mm, 35 mm, 40 mm

- 4 Duraklick XL Mounting Profile 1250 mm
- 5 Duraklick Aluminum Base Rail
Available in various lengths
- 6 Roof Protection Mat

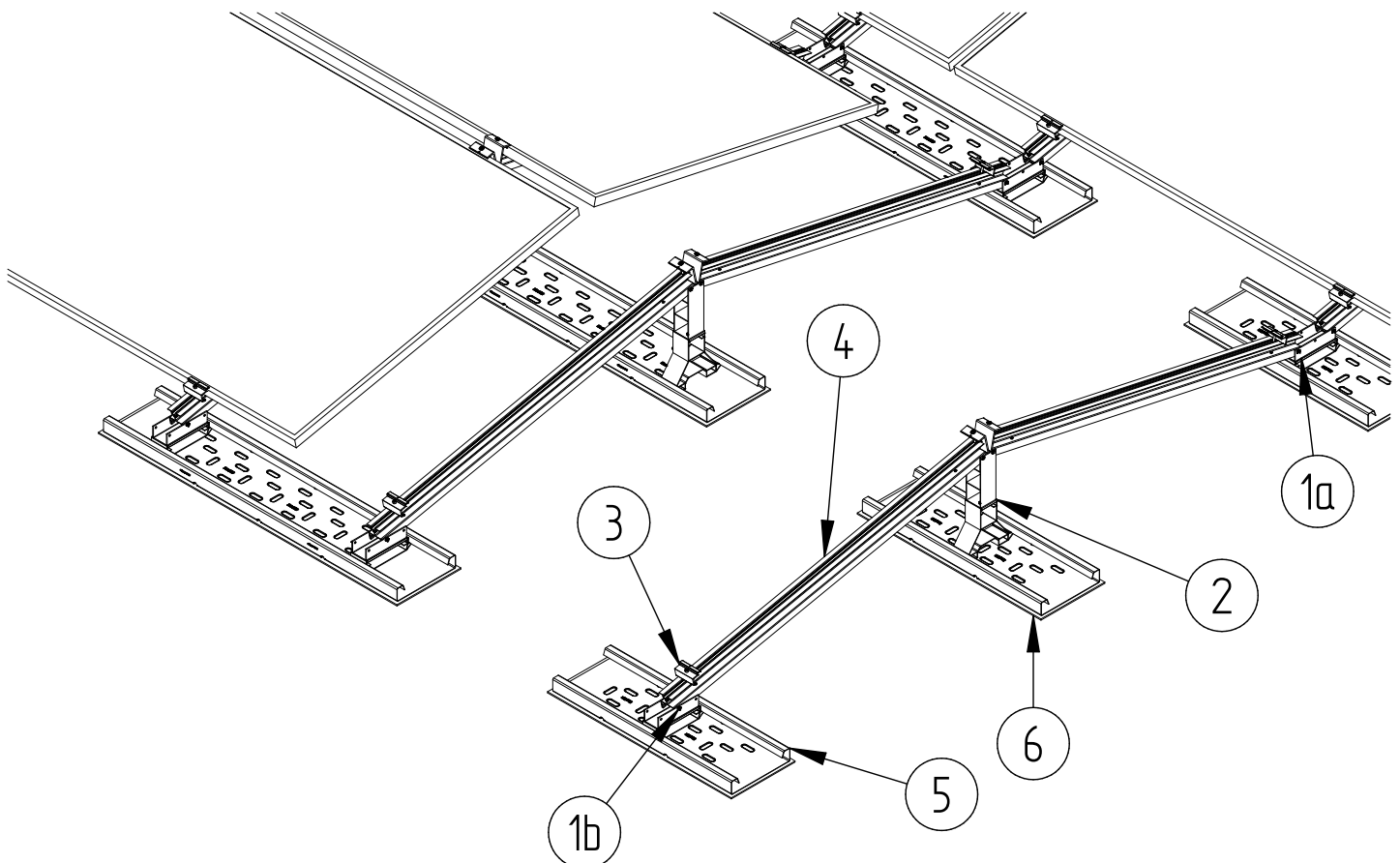

1.1. Module Field and Compensation Distance

1.1 Measuring the Module Field

Lay out the module field according to the installation plan.

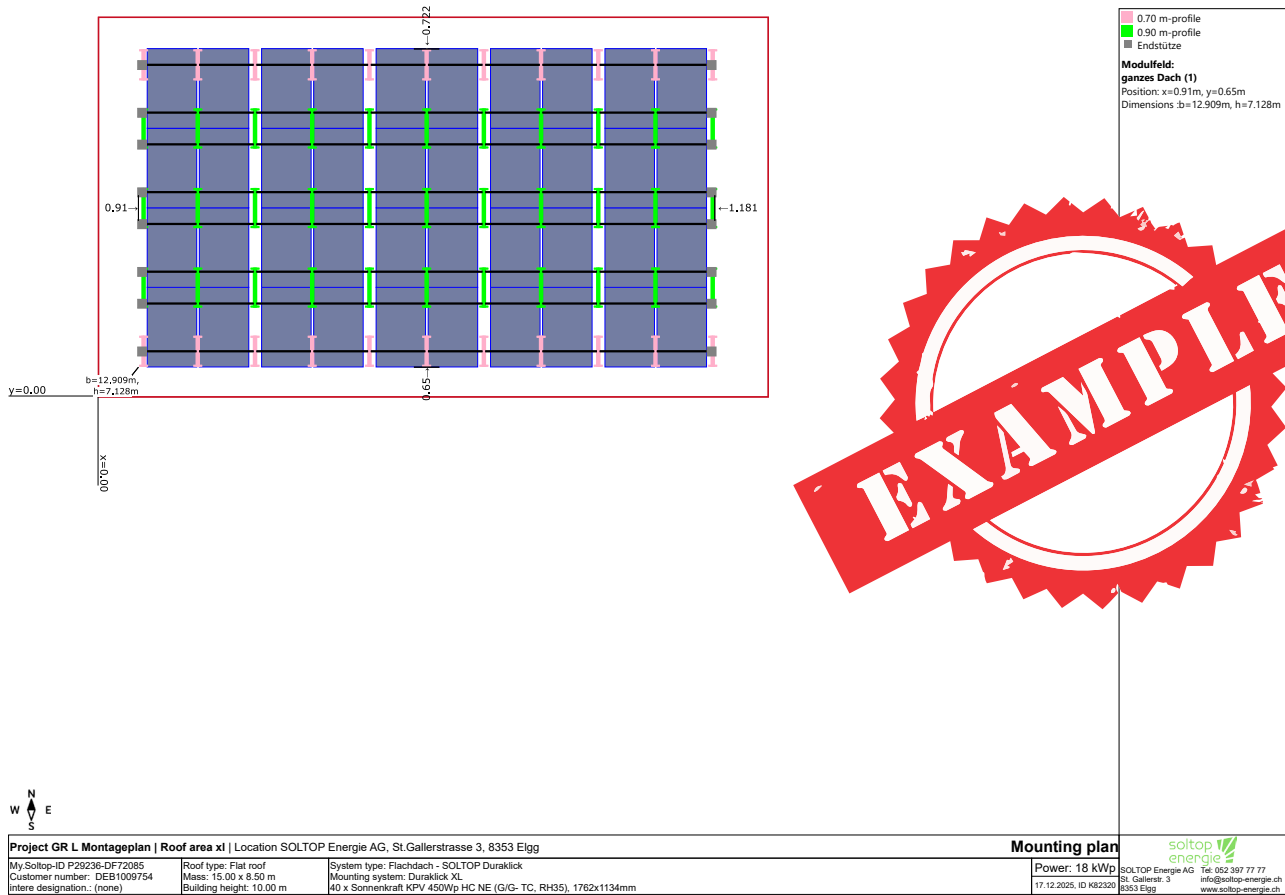

1.1.1 Compensation Distance

For all rows, the compensation distance is fixed at 2563 mm.

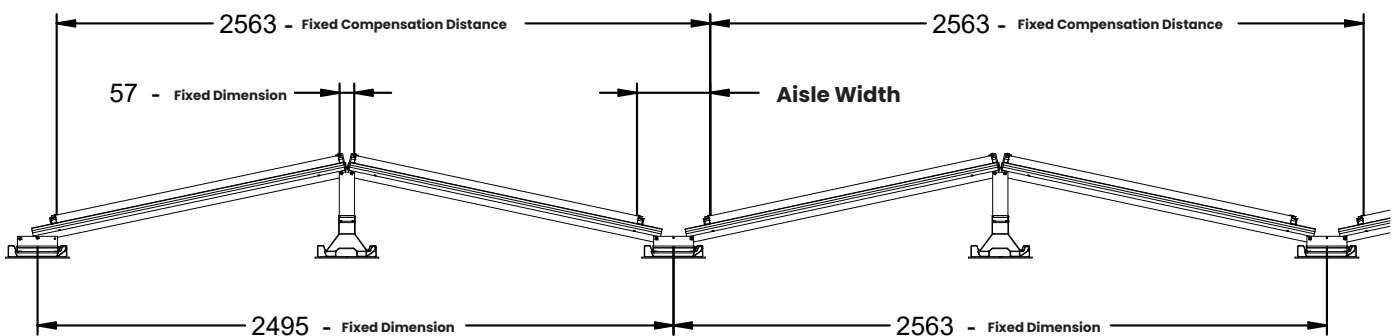

(applies at the beginning and end of a module field, as well as before and after any separation or interruption within the module field)

(Applies within the module field)

2. Installation of the Base Rails

2. Installation of the Supports

Position the upper and lower supports in the base rail according to the formula, then snap them into place.

2.1 Determine the Position of the Supports

The variables x , y , and z must be calculated using the formulas.

L = Module Length
A = Clamping Position

These values must be taken from the module manufacturer's installation manual.

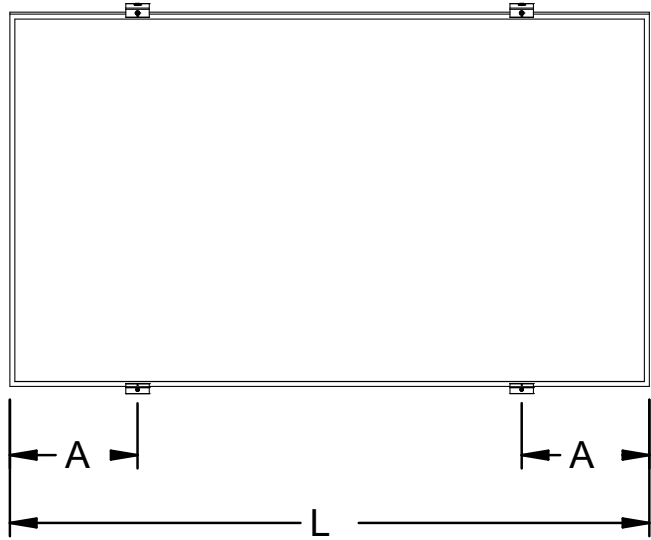

B = Length of the Central Base Rail

This value can be found in the installation plan.

Minimum dimensions must always be observed.

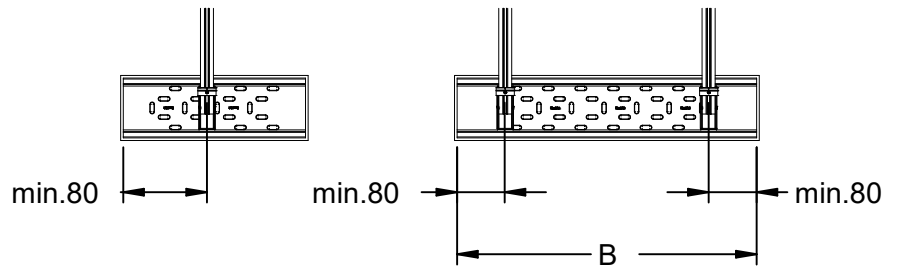

Determining the Positions of the Supports (values to be calculated)

x = distance between supports on the module
y = distance between the support and the next module
z = overhang of the base rail

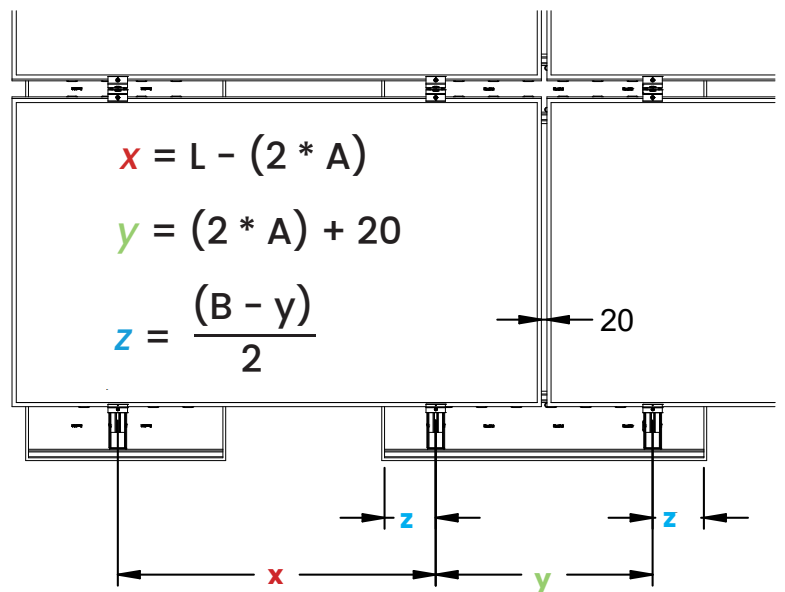

2.2 Installation of the Module Supports

2.2 Snap the supports into the base rails

Lower Supports

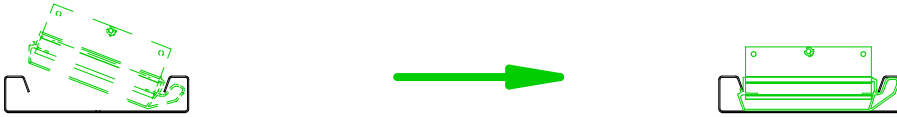

Upper Supports

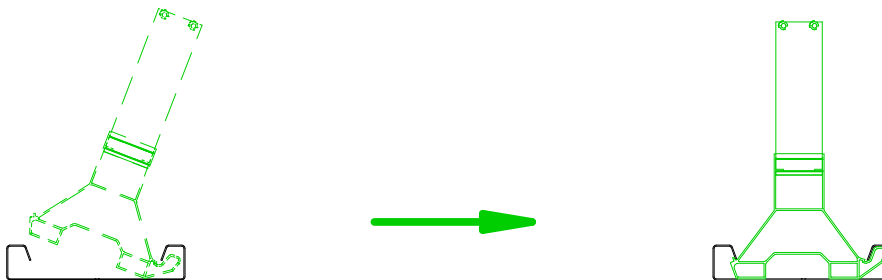

2.3 Definition of End Supports

End supports are „lower supports“ that:

...are located at the beginning or end of a module field,

... are positioned before or after any separation or interruption within the module field.

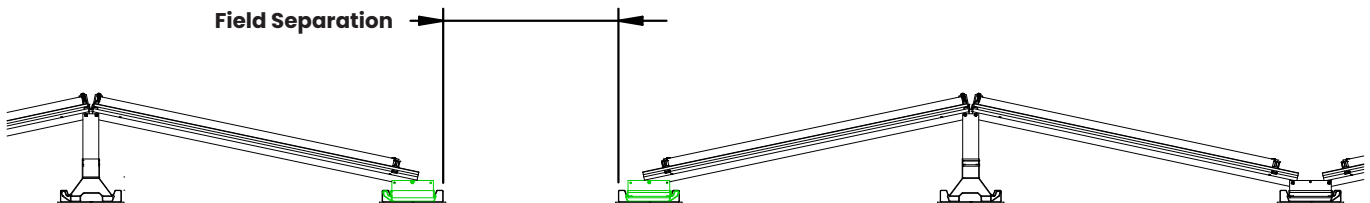

On the installation plan, the end supports are shown in gray.

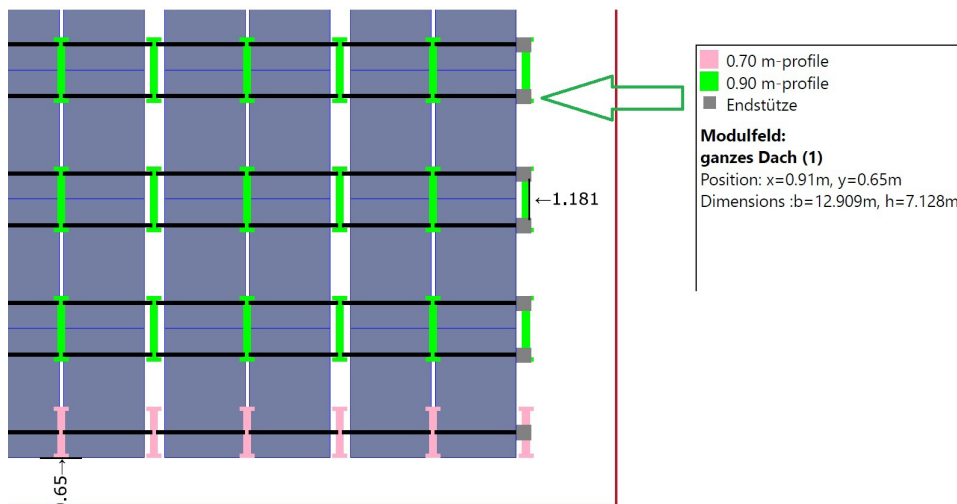

3. Base Rails and Protection Mats

3. Base Rails and Roof Protection Mats

3.1 Install the protection mats and base rails

The marked row and column must be placed and ballasted precisely using the installation plan. All other rows should initially be positioned only approximately. The protection mats must fully cover the entire length of all base rails (10 mm around). For membrane roofs, use film-coated protection mats.

Note:

The remaining protection mats will be aligned precisely during the installation of the profiles.

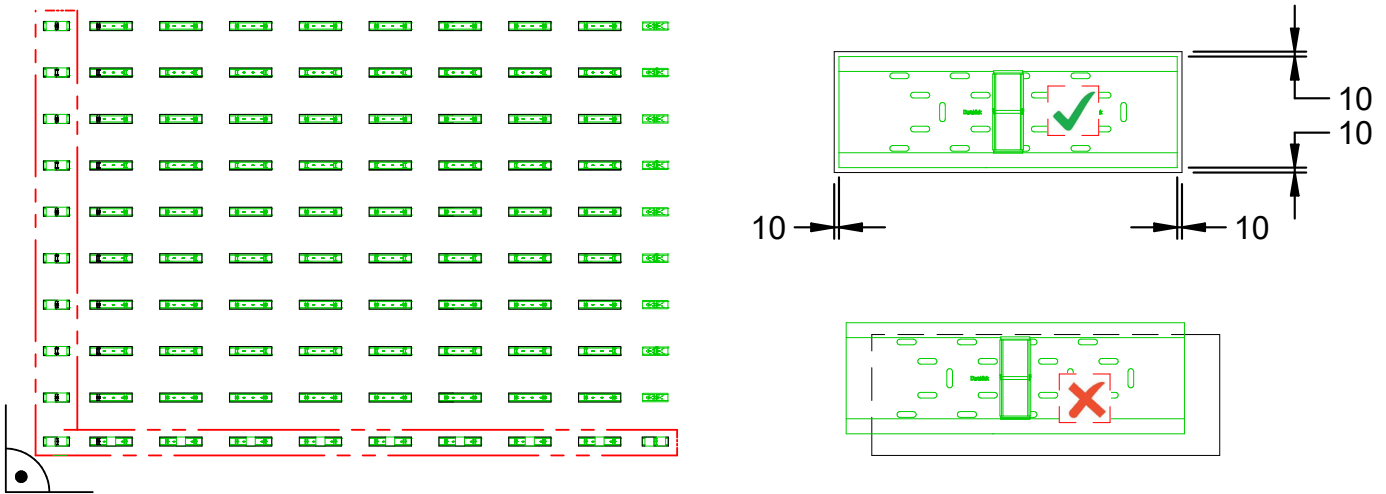

3.2 Glue the base rails to the protection mats

All 0.7 m base rails must be glued to the protection mats. Glue one punched hole on each side of the support.

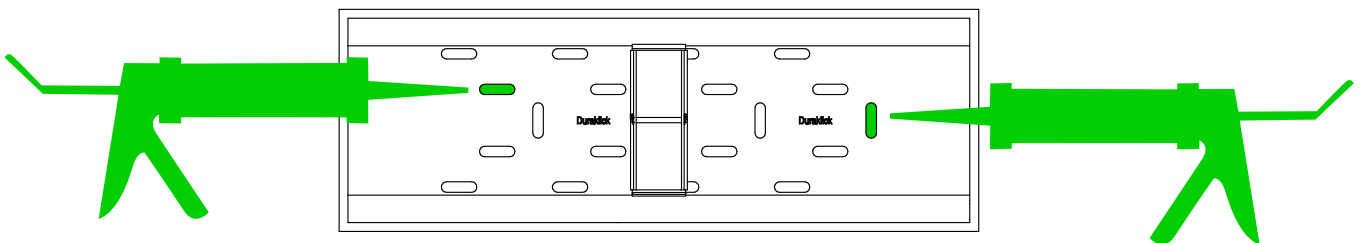

For roofs with a slope > 3°, uneven roofs, or lightly ballasted installations, it is recommended to glue all protection mats to the base rails.

In this case, the required amount of adhesive must be ordered as an option.

4. Installation of the Profiles

4. Installation of the Profiles

Snap the mounting profile into the upper and lower supports.

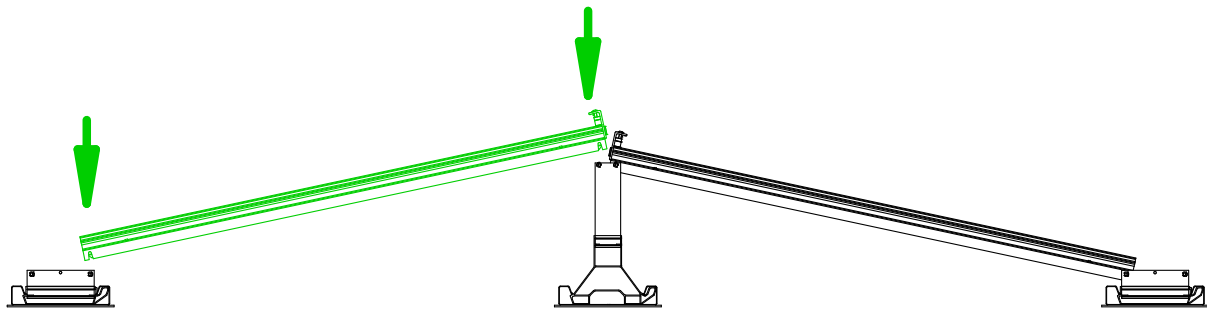

Install the profiles row by row and adjust the alignment of the base rails.

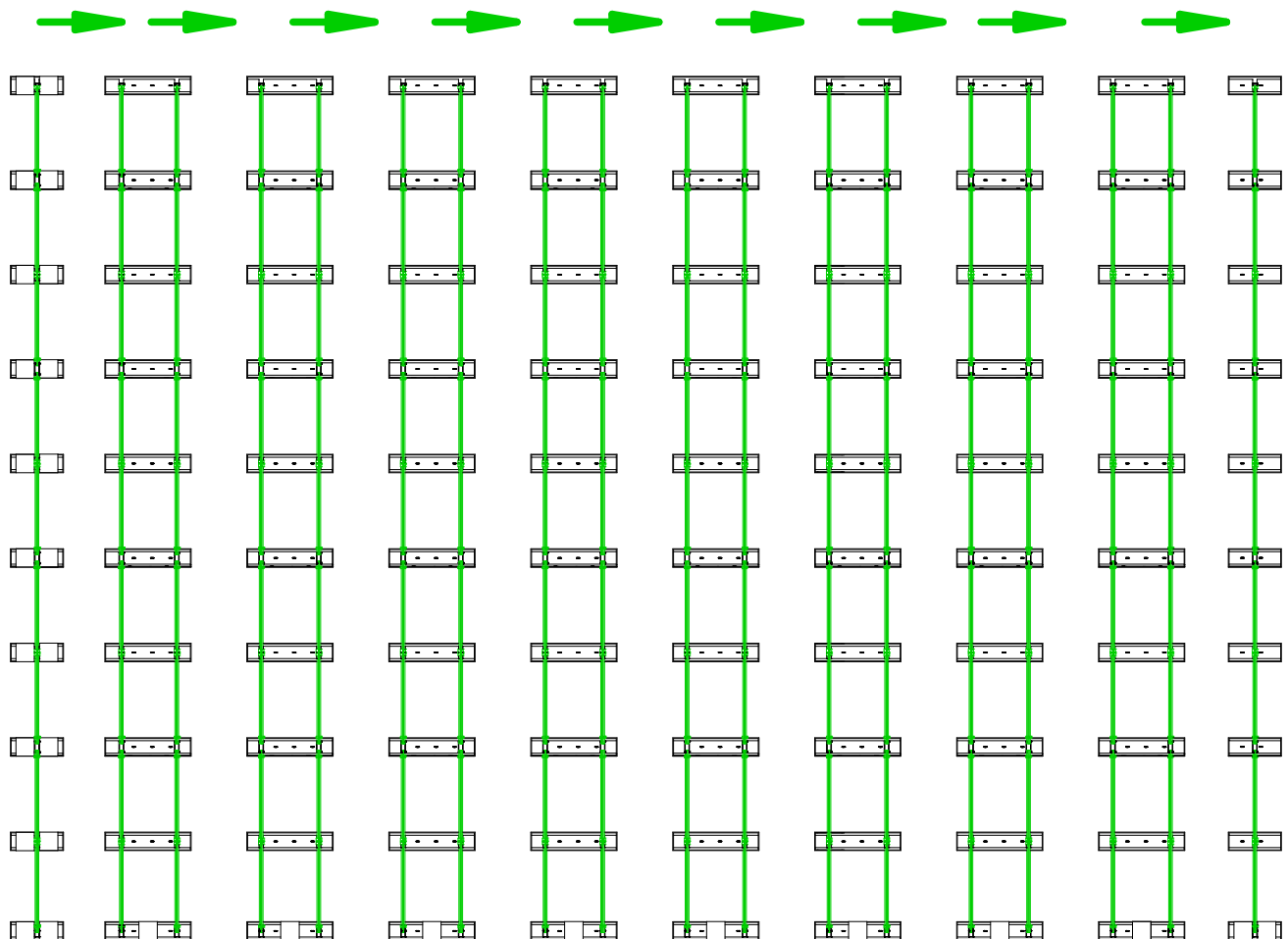

4.2 Removal of the profiles

4.2 Removal of the profiles

The profile is removed by actuating the two safety springs.



1. Gently pull the safety spring toward the center of the profile to release the locking mechanism.
2. Lift upwards.
3. For reassembly, ensure that the safety springs are returned to their original (closed) position.

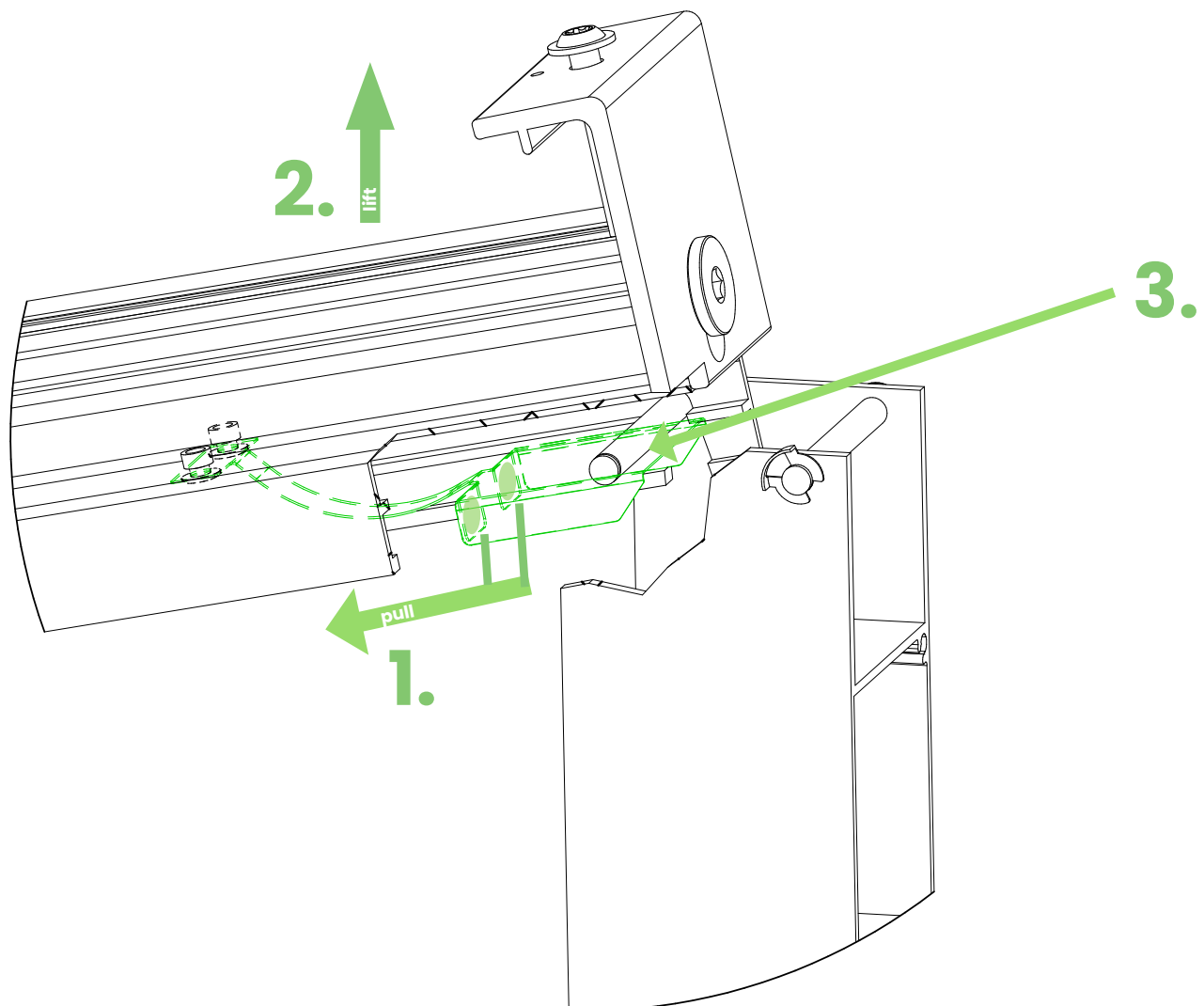



5. Ballasting

Position the elements according to the ballasting plan.
Distribute the ballast evenly across all base rails.

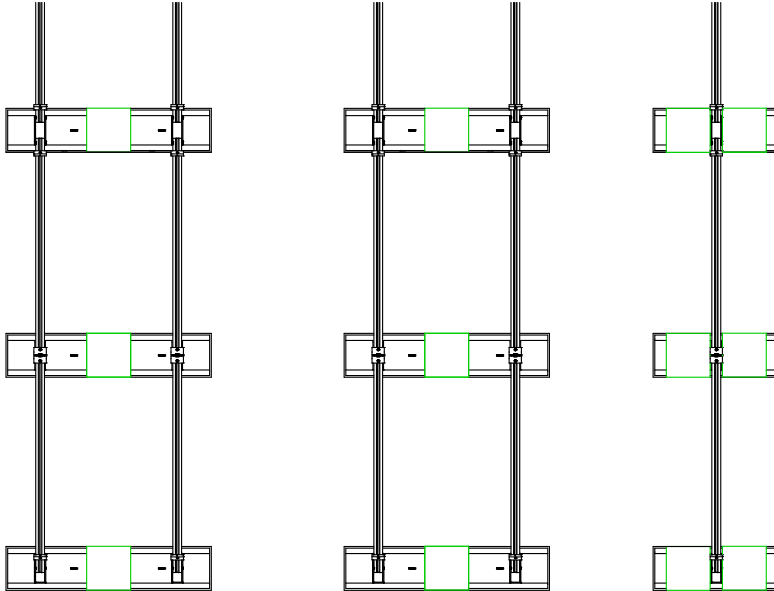

6. Module Installation

Push the module against the upper clamp stop.

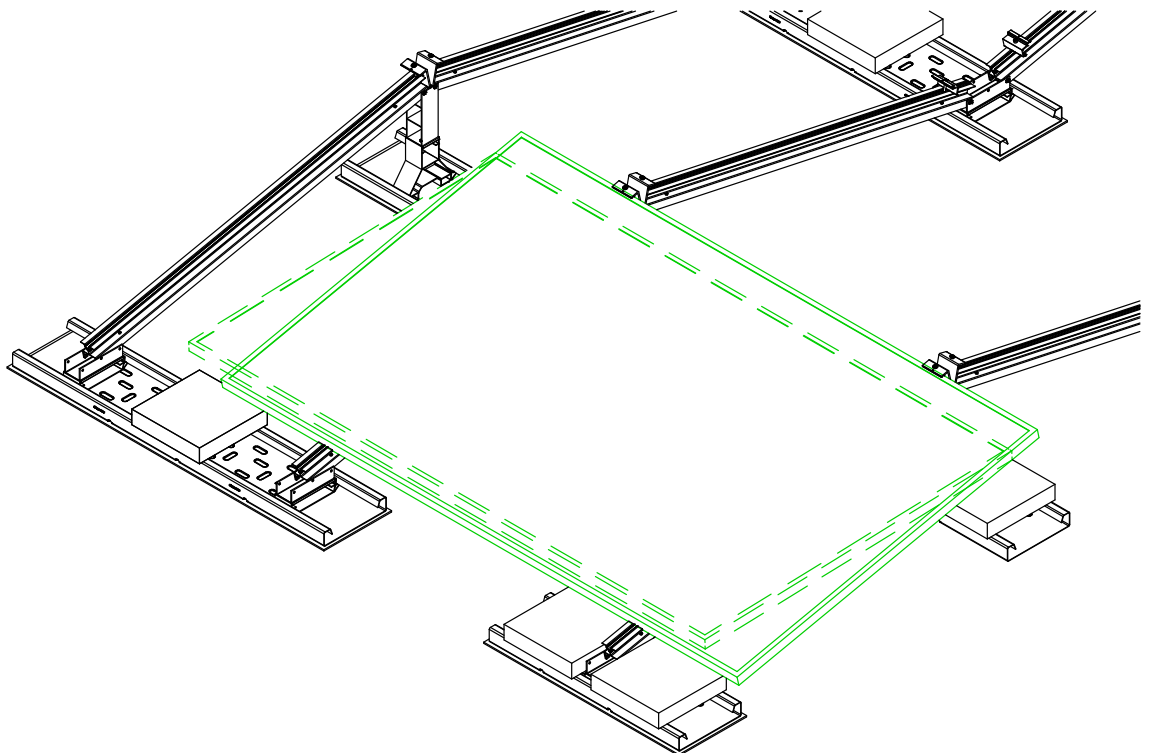

6. Module Installation

Tighten the upper clamps
(Observe the torque recommended by the manufacturer,
min. 10 Nm).

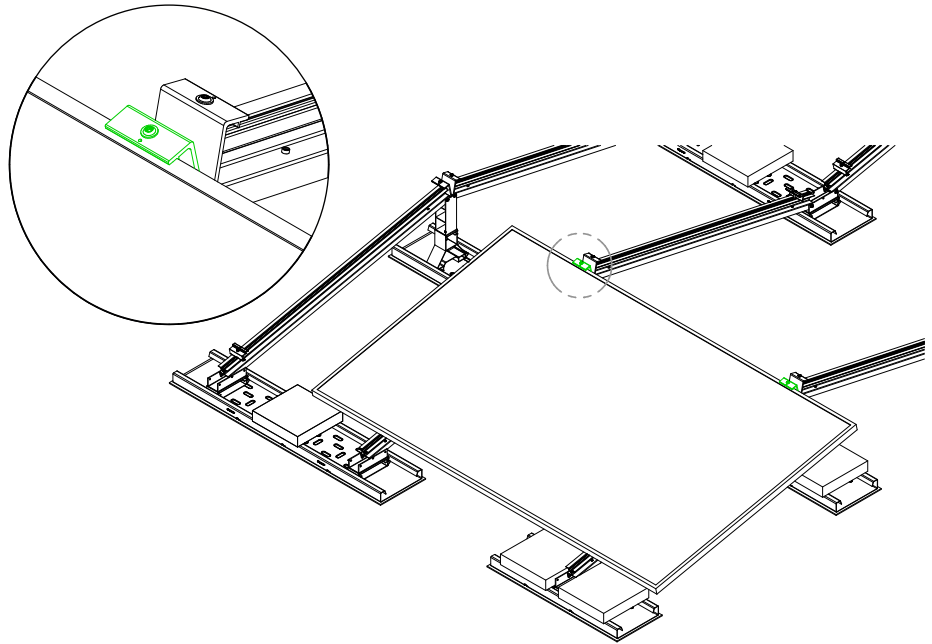

Snap the lower clamps into the mounting profile and tighten them
(Observe the torque recommended by the manufacturer, min. 10 Nm).

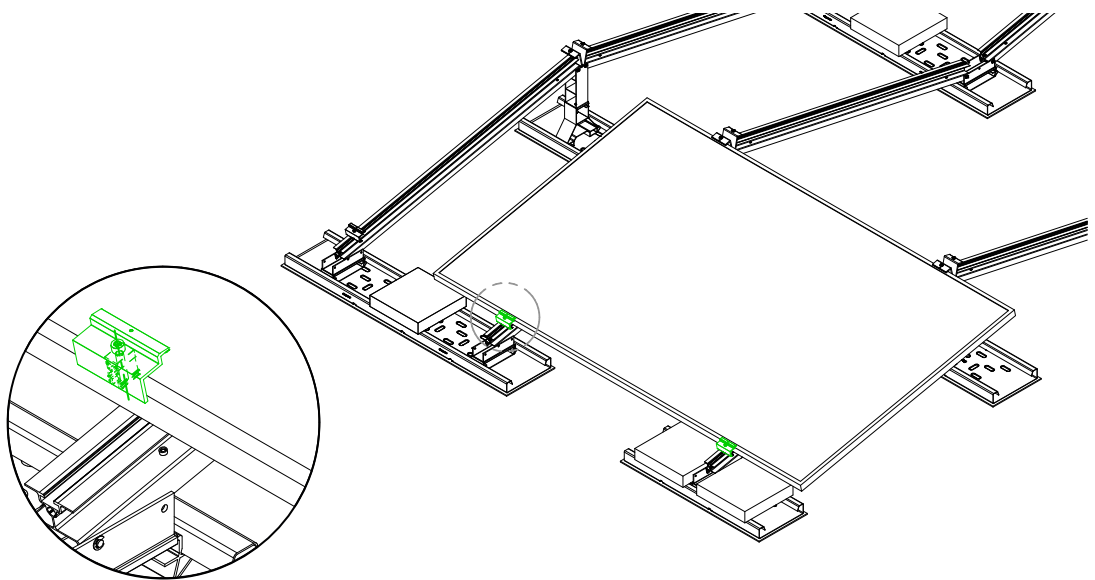

The distance between two modules is fixed at 20 mm.

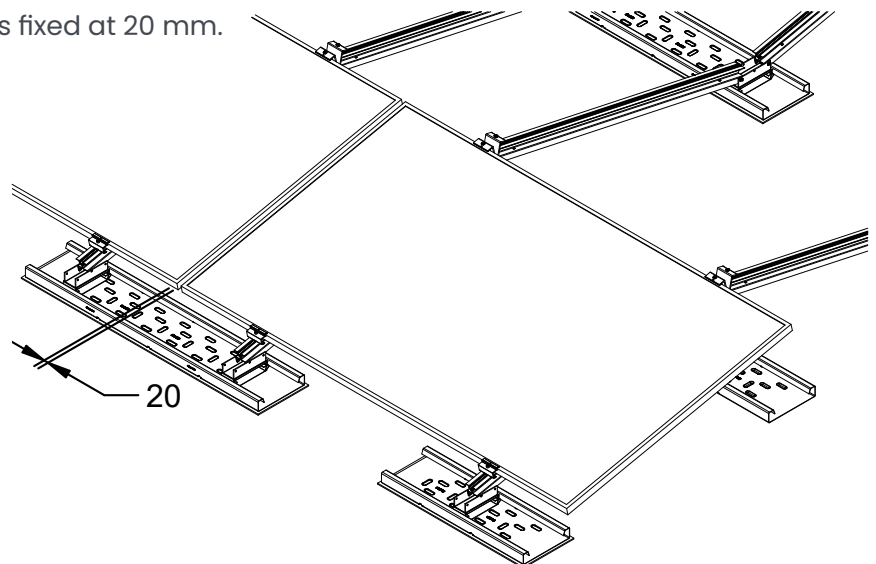

Disclaimer

Using the mounting system for purposes other than those intended voids all liability.

Warranty Conditions

The applicable statutory periods apply.

Manufacturer Information

The Duraklick XL flat roof system is manufactured by:

SOLTOP Energie GmbH
Lindauer Straße 15
D-88145 Hergatz

www.soltop-energie.eu



Duraklick



Garantie-Zertifikat

Auf alle von uns gelieferten Duraklick-Montagesysteme erhalten Sie

10 Jahre Haltbarkeitsgarantie auf alle Teile.

Wenn bei normaler Beanspruchung und trotz ordnungsgemäßer Installation und Handhabung ein Schaden auftritt, werden wir Ihnen innerhalb der Garantiefrist das betroffene Bauteil unverzüglich austauschen.

Die Verpflichtung zur Garantieleistung entfällt, wenn der Schaden im Zusammenhang mit aussergewöhnlicher Beanspruchung (z.B. Unwetter-schäden, Einwirkung durch Instabilität des Untergrunds, besondere chemische oder biologische Einwirkungen) entstanden ist, es sei denn, der Schaden wurde nachweislich nicht hierdurch, sondern wesentlich durch einen Material- oder Konstruktionsfehler verursacht. Für die Installation und Handhabung gelten die zu den jeweiligen Produkten von uns gelieferten technischen Produktbeschreibungen und Installationsanleitungen, die gesetzlich vorgeschriebenen oder allgemein anerkannten Normen und Grundsätze der Baukunst sowie gegebenenfalls vorrangig die von uns individuell für den Kunden gefertigten Pläne, Statiken und Anleitungen.

Die Garantie ist beschränkt auf die Nachlieferung von defekten Teilen bei Meldung des Schadens innerhalb der Garantiefrist. Etwaige gesetzliche Gewährleistungs- oder Haftungsansprüche bleiben unberührt.

Soweit für bestimmte Bauteile allgemein oder für eine bestimmte Art des Einsatzes eine mögliche kürzere Lebensdauer ausdrücklich angegeben oder im Rahmen von uns individuell erstellter Planungen ein Austausch binnen kürzerer Frist vorgesehen ist, ist die Garantiezeit auf diese Lebensdauer oder Frist beschränkt.

Sollte der Schaden durch eine Versicherung gegen Unwetter und ähnliche Ereignisse (Elementarversicherung) abgedeckt sein oder üblicherweise abgesichert werden können, bestehen keine Ansprüche.

Diese Garantie begründet nur Ansprüche unseres Vertragspartners, über den alle Garantiefälle abzuwickeln sind. Die Geltendmachung durch Dritte ist nur möglich, wenn wir dem zustimmen.
Im Übrigen gelten unsere Allgemeinen Geschäftsbedingungen in ihrer jeweils gültigen Fassung.



Weitere Informationen erhalten Sie auf www.soltop-energie.ch & www.soltop-energie.eu

SOLTOP Energie AG
St. Gallerstrasse 3
CH-8353 Elgg
info@soltop-energie.ch

SOLTOP Energie GmbH
Lindauer Straße 15
D-88145 Hergatz
info@soltop-energie.eu

SOLTOP Energie SA
Rue des Sablons 8
CH-3960 Sierre
info.fr@soltop-energie.ch

SOLTOP Energie SA
Avenue Haldimand 41
CH-1400 Yverdon-les-Bains
info@soltop-energie.ch



Further information can be found at www.soltop-energie.ch & www.soltop-energie.eu



XL Flat Roof System Installation Instructions

© SOLTOP Energie GmbH • XL Installation Guide (FR) • Printed in Germany • Subject to change.



Further information can be found at www.soltop-energie.ch & www.soltop-energie.eu

SOLTOP Energie AG
St. Gallerstrasse 3
CH-8353 Elgg
info@soltop-energie.ch

SOLTOP Energie GmbH
Lindauer Straße 15
D-88145 Hergatz
info@soltop-energie.eu

SOLTOP Energie SA
Rue des Sablons 8
CH-3960 Sierre
info.fr@soltop-energie.ch

SOLTOP Energie SA
Avenue Haldimand 41
CH-1400 Yverdon-les-Bains
info@soltop-energie.ch